

# MPF PRODUCTS INC.

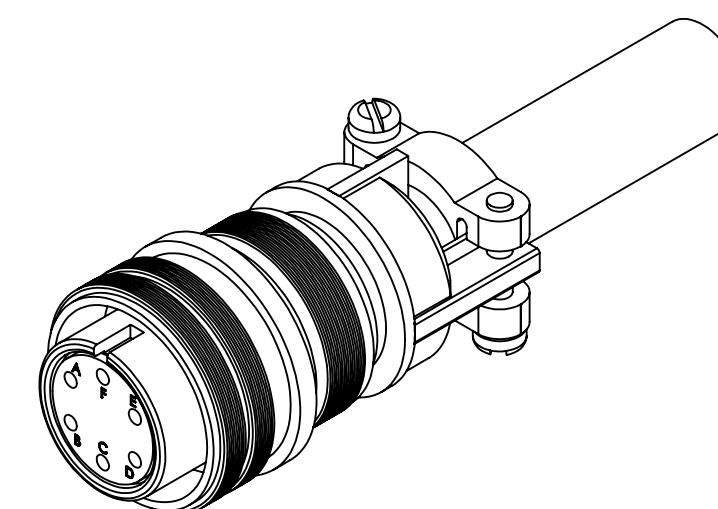
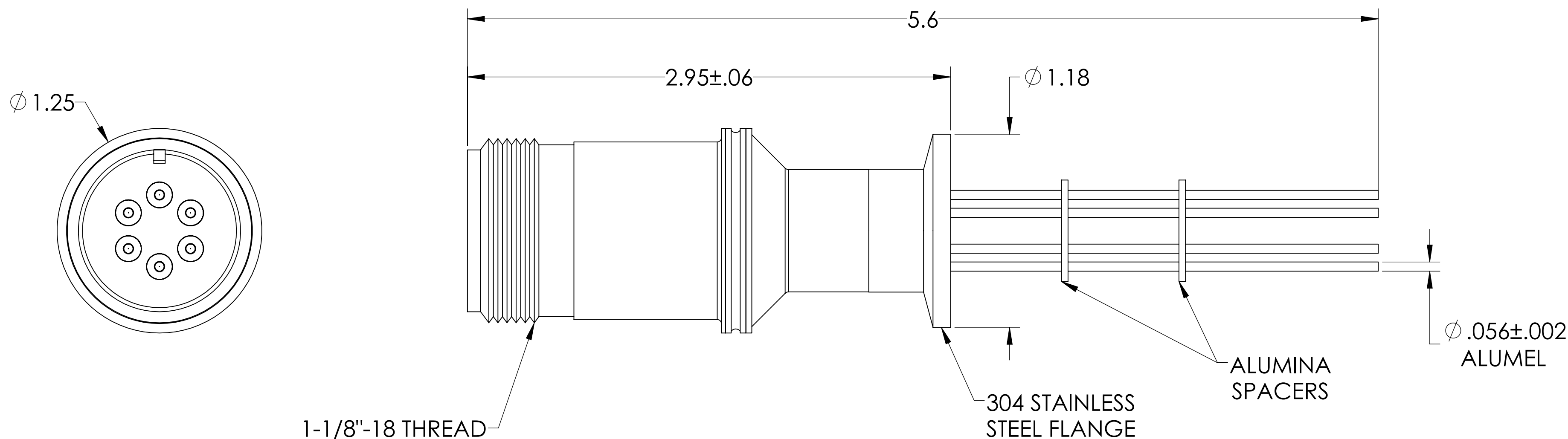
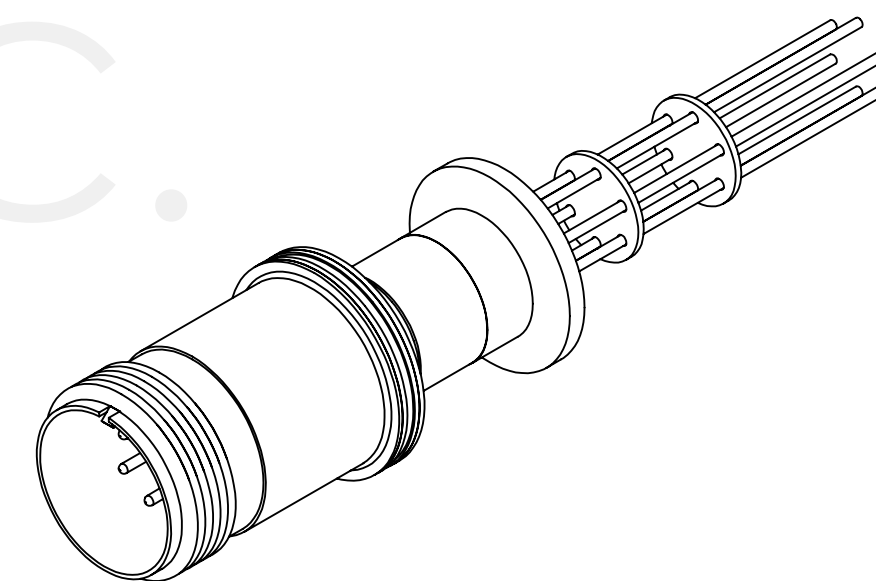

**SPECIFICATIONS:**

1. VOLTAGE: 700 VOLTS DC
2. CURRENT: 10 AMPS PER PIN, 36 AMPS FULL LOAD
3. TEMPERATURE RATING: -100 TO 450°C WITHOUT CONNECTOR
4. LEAK RATE <math> < 1 \times 10^{-9}</math> ATM CC/SEC HE

MS Series, Multipin Feedthrough, 6 Pins, 700 Volts, 10 Amps per Pin, 0.056" Dia Conductors w/ Air-side Connector, 1.18" QF/KF

UNLESS OTHERWISE SPECIFIED:		QUOTATION #		N/A		
DIMENSIONS ARE IN INCHES		NAME	DATE	MPF PRODUCTS INC.		
TOLERANCES:		DRAWN	WJ			9/11/2015
ANGULAR: MACH $\pm 1/2^\circ$		CHECKED	WJ			9/11/2015
TWO PLACE DECIMAL $\pm .030$		ENG APPR.	WJ			9/11/2015
THREE PLACE DECIMAL $\pm .015$		THIRD ANGLE:		TITLE:		
MATERIAL				MULTIPIN, 6 PINS, 700V, 10A, 1.18 QF/KF		
FINISH		APPLICATION		NEXT ASSY		
PLATING		SURFACE FINISH: $\sqrt{63}$ OR BETTER		USED ON		
		UNLESS OTHERWISE SPECIFIED:		DOWNLOADED FROM MPFPI.COM		
		ALL DIAMETERS CONCENTRIC WITHIN .005.		DWG. NO. A0197-8-QF		
		REMOVE ALL BURRS AND SHARP EDGES		REV.		
		Thursday, February 7, 2019 8:25:07 AM				