

# MPF PRODUCTS INC.

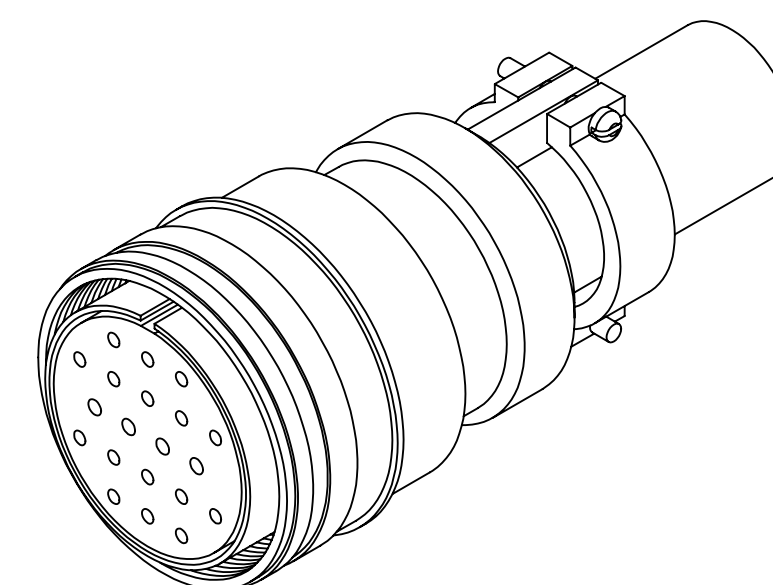
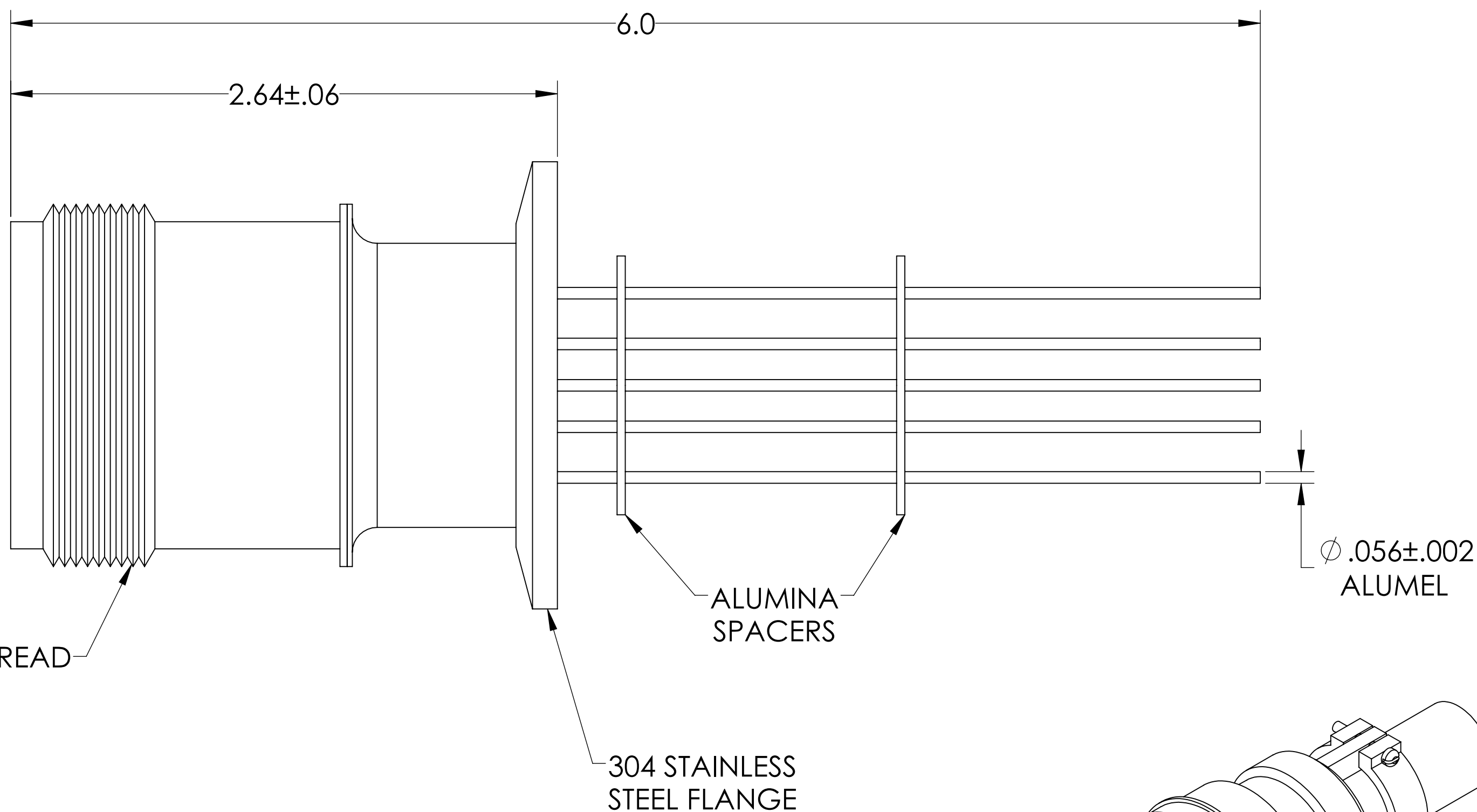
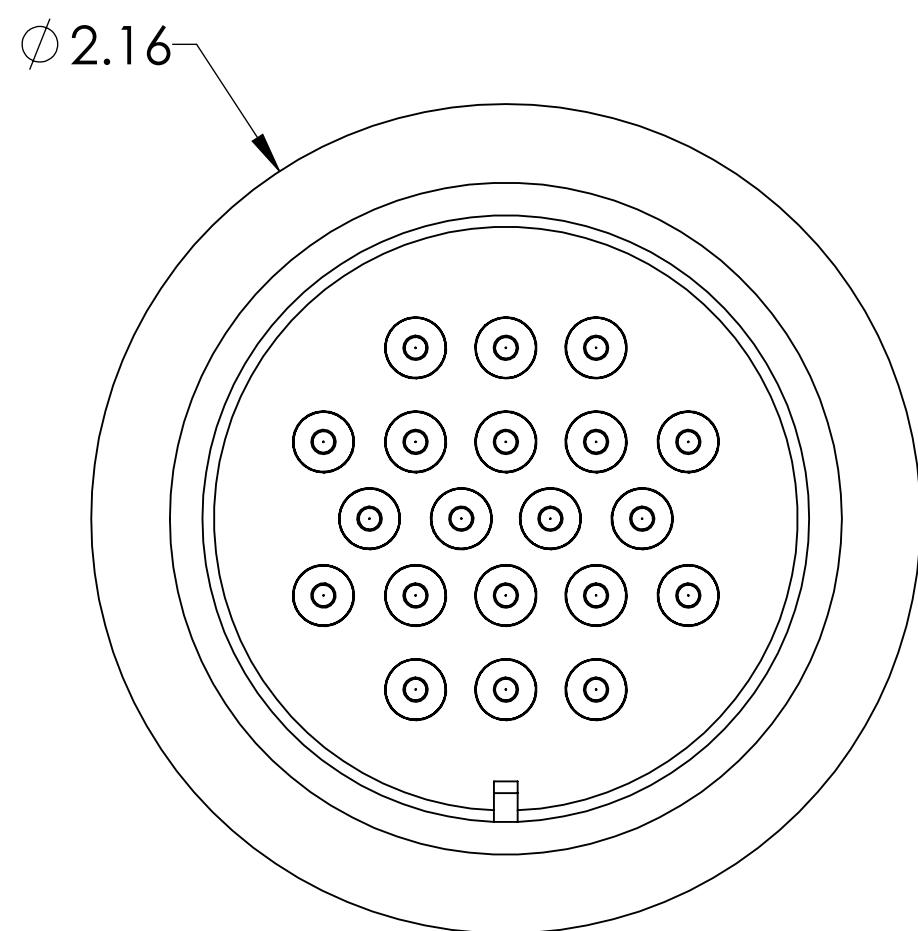
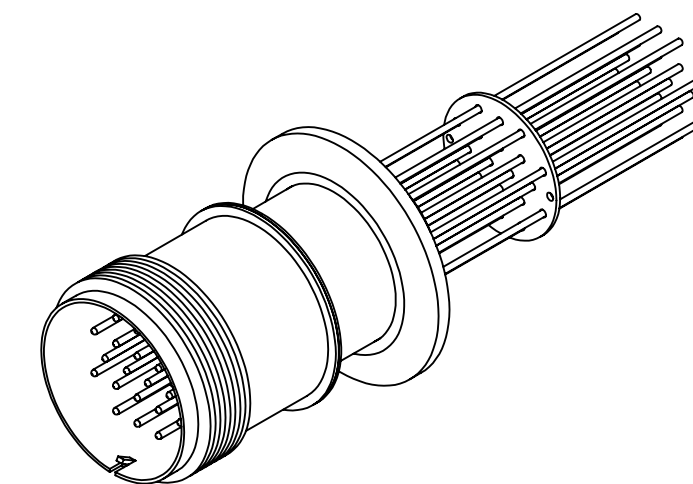

**SPECIFICATIONS:**

1. VOLTAGE: 700 VOLTS DC
2. CURRENT: 10 AMPS PER PIN, 75 AMPS FULL LOAD
3. TEMPERATURE RATING: -100 TO 450°C WITHOUT CONNECTOR
4. LEAK RATE < 1X10-9 ATM CC/SEC HE

MS Series, Multipin Feedthrough, 20 Pins, 700 Volts, 10 Amps per Pin, 0.056" Dia Conductors w/ Air-side Connector, 2.16" QF/KF

UNLESS OTHERWISE SPECIFIED:		QUOTATION #		N/A	
DIMENSIONS ARE IN INCHES TOLERANCES:		NAME	DATE	<b>MPF PRODUCTS INC.</b>	
ANGULAR: MACH ± 1/2°		DRAWN	9/11/2015		
TWO PLACE DECIMAL ± .030		CHECKED	9/11/2015		
THREE PLACE DECIMAL ± .015		ENG APPR.	9/11/2015		
MATERIAL		THIRD ANGLE:		TITLE:  <b>MULTIPIN, 20 PINS, 700V, 10A, 2.16" QF/KF</b>	
FINISH					
PLATING		APPLICATION		DOWNLOADED FROM MPFPI.COM	
		NEXT ASSY	USED ON	DWG. NO.	
		SURFACE FINISH: 63 OR BETTER		A0209-4-QF	
		UNLESS OTHERWISE SPECIFIED:		REV	
		ALL DIAMETERS CONCENTRIC WITHIN .005. REMOVE ALL BURRS AND SHARP EDGES		Thursday, January 24, 2019 3:15:12 PM	