

MPF PRODUCTS INC.

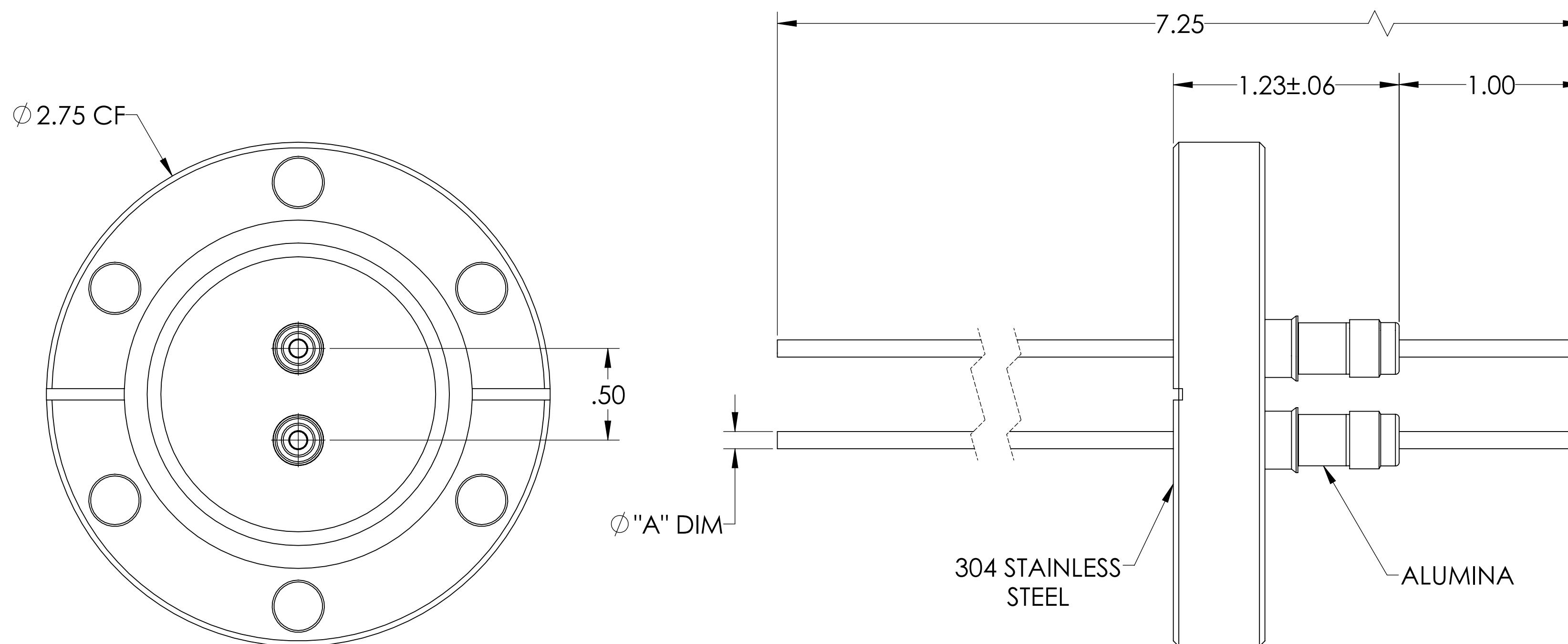
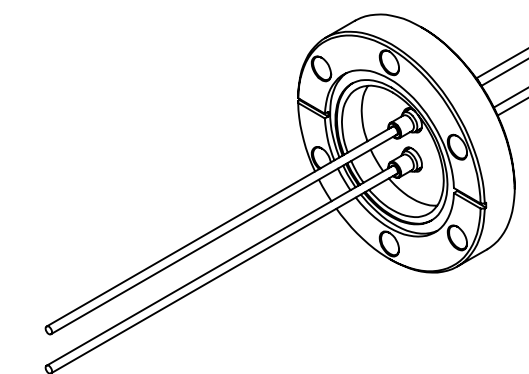

PART #	CONDUCTOR MATERIAL	"A" DIM	CURRENT RATING
A0279-1-CF	NICKEL 200	.092	15 AMPS
A0279-2-CF	OFHC COPPER	.094	50 AMPS
A0279-5-CF	MOLYBDENUM	.094	28 AMPS

NOTE:

1. VOLTAGE: 5000 VOLTS DC
2. CURRENT: SEE TABLE
3. TEMPERATURE RATING: -100 TO 450°C

Power Feedthrough, 5000 Volts, 2 Pins, 2.75" Conflat Flange, UHV Rated, Bakeable to 450°C

UNLESS OTHERWISE SPECIFIED:		QUOTATION #		N/A	
DIMENSIONS ARE IN INCHES TOLERANCES:		NAME	DATE	MPF PRODUCTS INC.	
ANGULAR: MACH ± 1/2°		DRAWN	9/11/2015		
TWO PLACE DECIMAL ± .030		CHECKED	9/11/2015		
THREE PLACE DECIMAL ± .015		ENG APPR.	9/11/2015		
MATERIAL		THIRD ANGLE:		POWER FEEDTHROUGH, 5000 VOLTS, 2 PINS, 2.75" CONFLAT FLANGE	
FINISH		APPLICATION			
PLATING		NEXT ASSY	USED ON		
		SURFACE FINISH: 63/ OR BETTER			
		UNLESS OTHERWISE SPECIFIED:		DOWNLOADED FROM MPFPI.COM	
		ALL DIAMETERS CONCENTRIC WITHIN .005. REMOVE ALL BURRS AND SHARP EDGES		DWG. NO. A0279	
				REV	
				Monday, December 3, 2018 10:29:38 AM	