

MPF PRODUCTS INC.

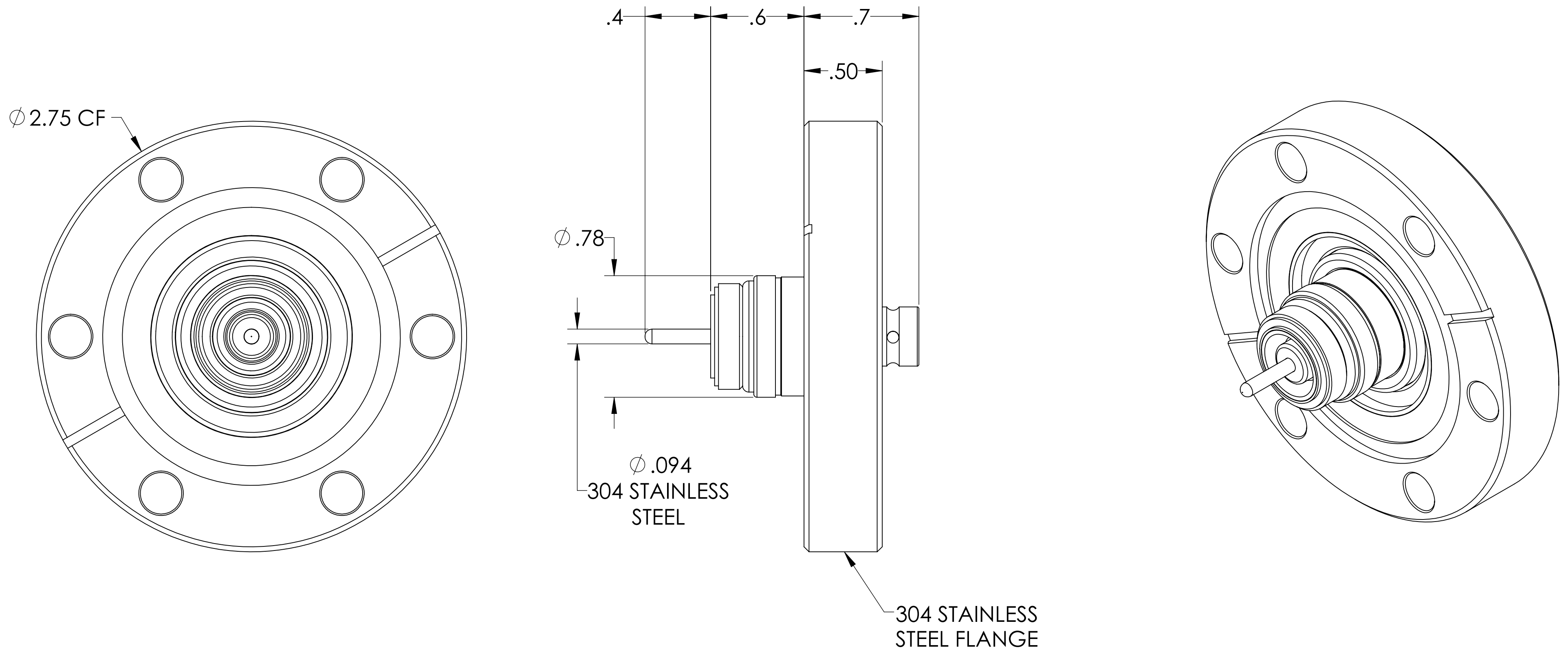

PART #	AIRSIDE CONNECTOR INCLUDED
A0304-1-CF	YES
A0304-2-CF	NO

NOTE:

1. SHIELD: FLOATING
2. VOLTAGE: 2500 VOLTS DC SHIELD TO GROUND, 500V PIN TO SHEILD
3. CURRENT: 3 AMPS
4. TEMPERATURE RATING: -200 TO 450°C (FEEDTHROUGH), 65 TO 165°C (AIRSIDE CONNECTOR)
5. IMPEDANCE: NON-CONSTANT

BNC Coaxial Feedthrough, 1 Pins, Floating Shield, 2.75" Conflat Flange, UHV Compatible

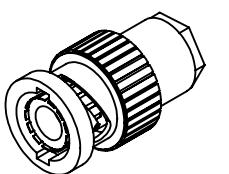

UNLESS OTHERWISE SPECIFIED:	QUOTATION #	N/A	
DIMENSIONS ARE IN INCHES TOLERANCES:	DRAWN	NAME	DATE
ANGULAR: MACH ± 1/2°	WJ	WJ	9/11/2015
TWO PLACE DECIMAL ± .030	CHECKED		9/11/2015
THREE PLACE DECIMAL ± .015	ENG APPR.	WJ	9/11/2015
MATERIAL	THIRD ANGLE:		
FINISH	APPLICATION		
PLATING	SURFACE FINISH:	63 OR BETTER	
	UNLESS OTHERWISE SPECIFIED:	ALL DIAMETERS CONCENTRIC WITHIN .005. REMOVE ALL BURRS AND SHARP EDGES	
	DOWNLOADED FROM MPFPI.COM	DWG. NO. A0304 REV	
	Friday, January 18, 2019 8:14:26 AM		