

MPF PRODUCTS INC.

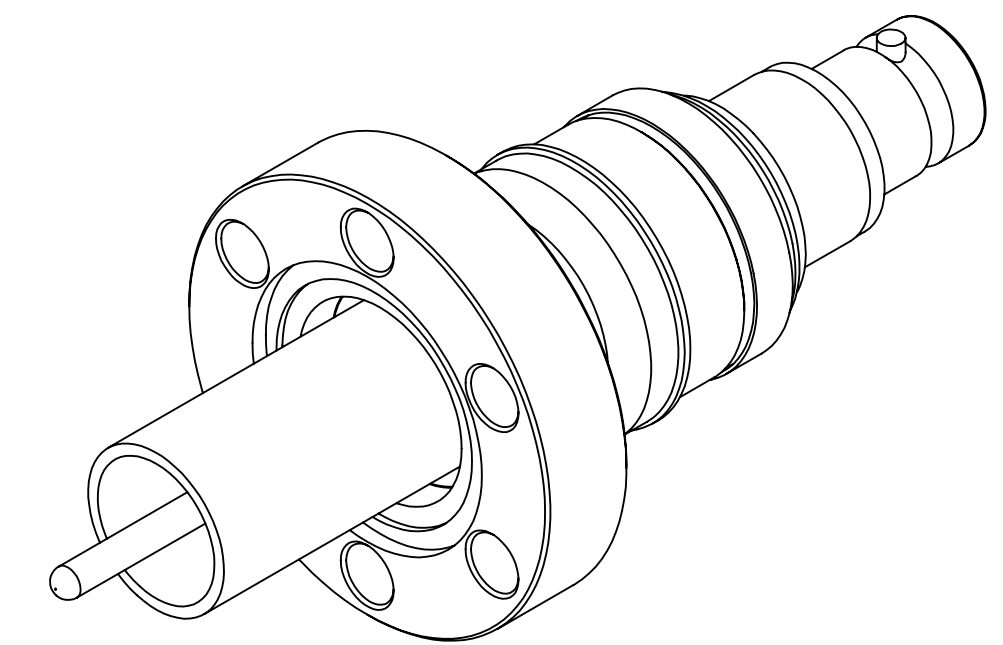
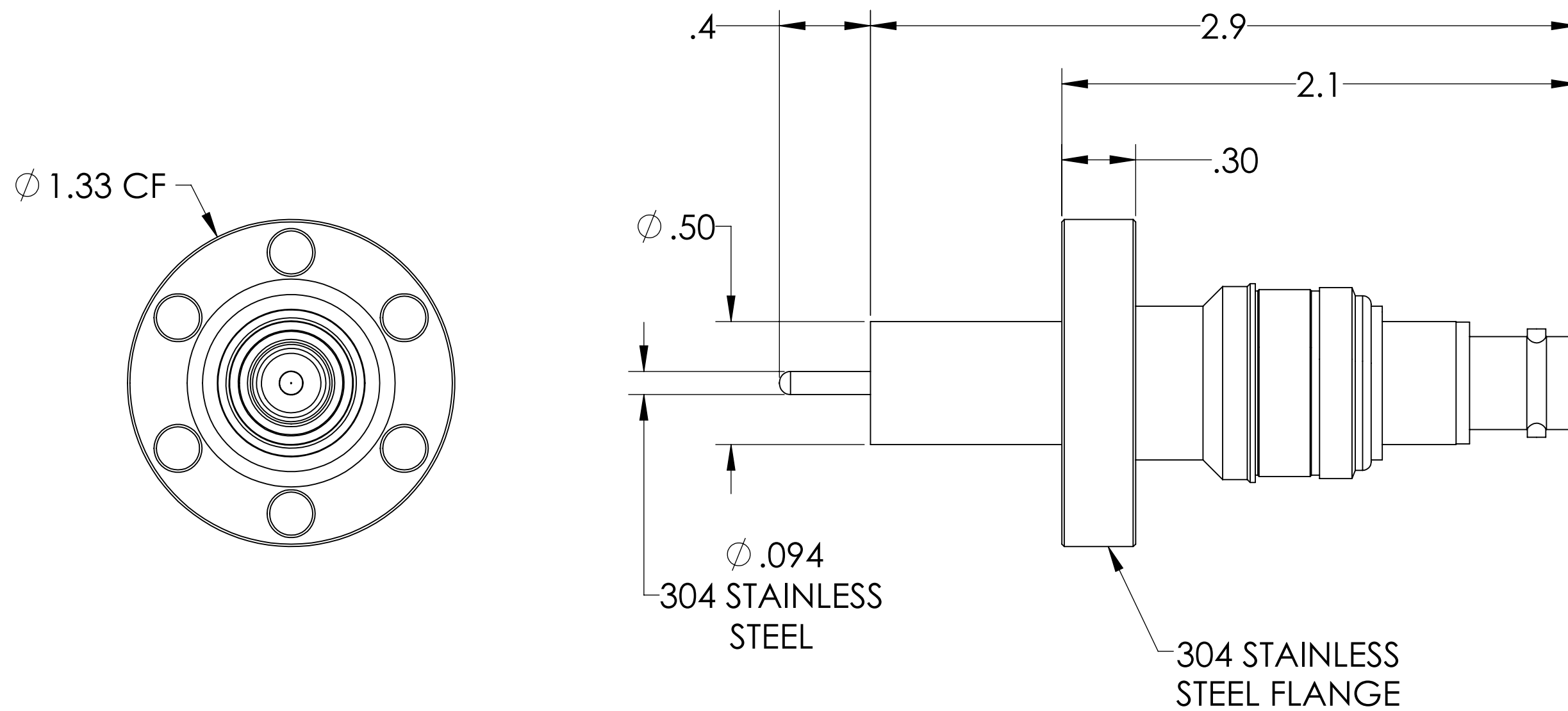

PART #	AIRSIDE CONNECTOR INCLUDED
A0310-1-CF	YES
A0310-2-CF	NO

NOTE:

1. SHIELD: FLOATING
2. VOLTAGE: 2500 VOLTS DC SHIELD TO GROUND, 500V PIN TO SHEILD
3. CURRENT: 3 AMPS
4. TEMPERATURE RATING: -200 TO 450°C (FEEDTHROUGH), 65 TO 165°C (AIRSIDE CONNECTOR)
5. IMPEDANCE: NON-CONSTANT

BNC Coaxial Feedthrough, 1 Pins, Floating Shield, 1.33" Conflat Flange, UHV Compatible

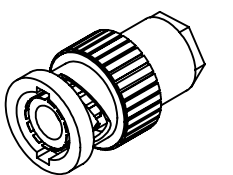

UNLESS OTHERWISE SPECIFIED:	QUOTATION #	N/A
DIMENSIONS ARE IN INCHES TOLERANCES:	NAME	DATE
ANGULAR: MACH ± 1/2°	WJ	9/11/2015
TWO PLACE DECIMAL ± .030	CHECKED	9/11/2015
THREE PLACE DECIMAL ± .015	ENG APPR.	WJ 9/11/2015
MATERIAL	THIRD ANGLE:	
	APPLICATION	
	NEXT ASSY	USED ON
FINISH	SURFACE FINISH:	63 OR BETTER
PLATING	UNLESS OTHERWISE SPECIFIED:	
	ALL DIAMETERS CONCENTRIC WITHIN .005. REMOVE ALL BURRS AND SHARP EDGES	
	TITLE:	MPF PRODUCTS INC.
		BNC COAXIAL FEEDTHROUGH, 1 PIN, FLOATING SHIELD, 1.33" CONFLAT FLANGE
	DOWNLOADED FROM MPFPI.COM	
	DWG. NO.	A0310
	REV	
	Friday, January 18, 2019 8:21:04 AM	