

# MPF PRODUCTS INC.

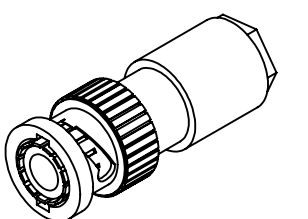
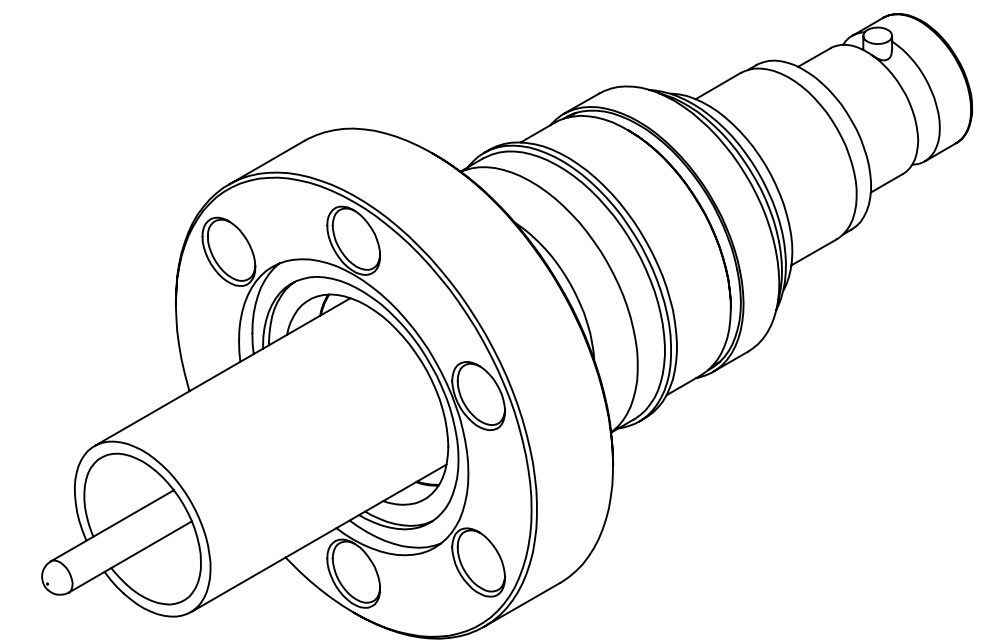
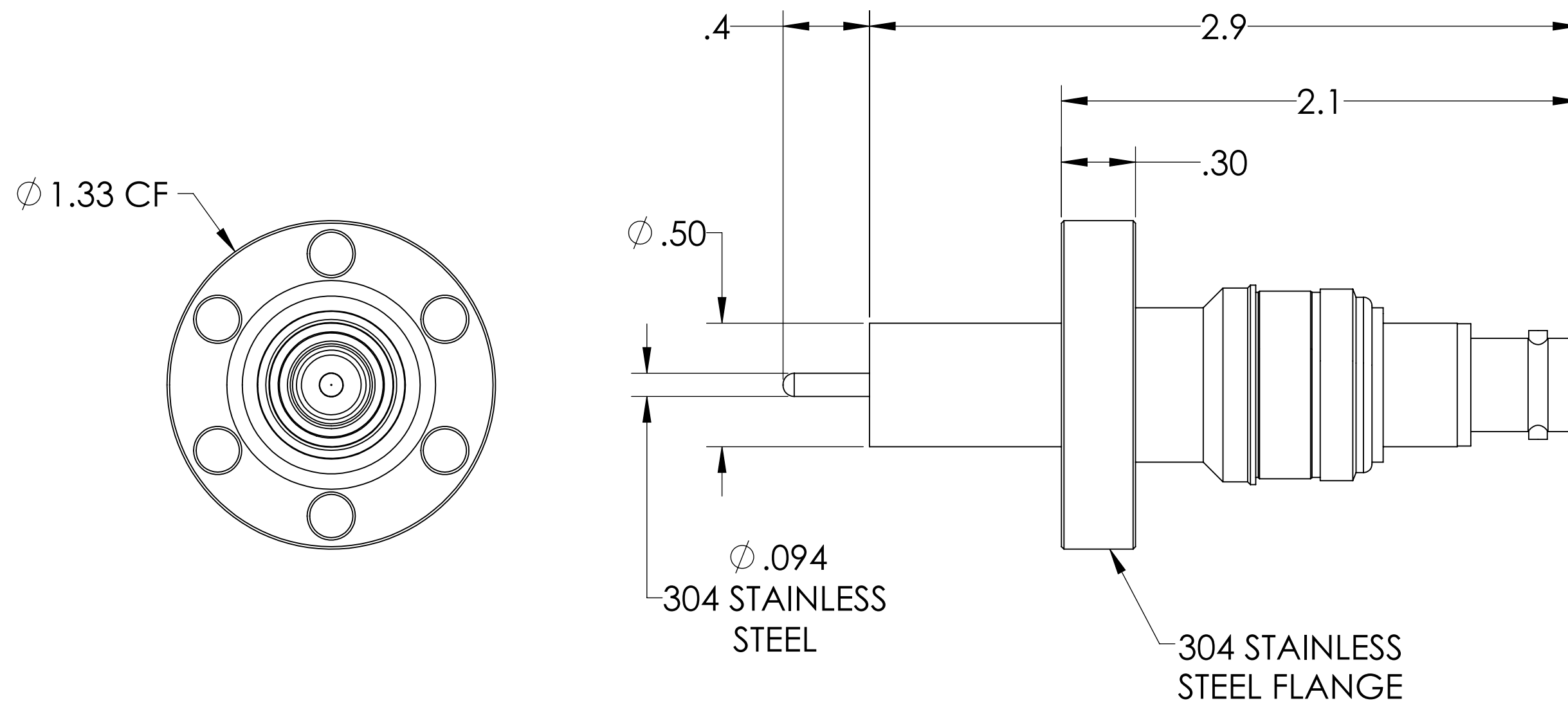

PART #	AIRSIDE CONNECTOR INCLUDED
A0311-1-CF	YES
A0311-2-CF	NO

**NOTE:**

1. SHIELD: FLOATING
2. VOLTAGE: 2500 VOLTS DC SHIELD TO GROUND, 5000V PIN TO SHEILD
3. CURRENT: 3 AMPS
4. TEMPERATURE RATING: -200 TO 450°C (FEEDTHROUGH), 65 TO 165°C ( AIRSIDE CONNECTOR)
5. IMPEDANCE: NON-CONSTANT

MHV Coaxial Feedthrough, 1 Pin, Floating Shield, 1.33" Conflat Flange, UHV Compatible

UNLESS OTHERWISE SPECIFIED:	QUOTATION #	N/A
DIMENSIONS ARE IN INCHES TOLERANCES:	NAME	DATE
ANGULAR: MACH ± 1/2°	WJ	9/11/2015
TWO PLACE DECIMAL ± .030	CHECKED	9/11/2015
THREE PLACE DECIMAL ± .015	ENG APPR.	WJ 9/11/2015
MATERIAL	THIRD ANGLE:	
FINISH	APPLICATION	
PLATING	NEXT ASSY	USED ON
	SURFACE FINISH: 63 OR BETTER	
	UNLESS OTHERWISE SPECIFIED:	
	ALL DIAMETERS CONCENTRIC WITHIN .005. REMOVE ALL BURRS AND SHARP EDGES	
	MPF PRODUCTS INC.	
	TITLE: MHV COAXIAL FEEDTHROUGH, 1 PIN, FLOATING SHIELD, 1.33" CONFLAT FLANGE	
	DOWNLOADED FROM MPFPI.COM	
	DWG. NO.	REV
	A0311	
	Friday, January 18, 2019 8:11:50 AM	