

# MPF PRODUCTS INC.

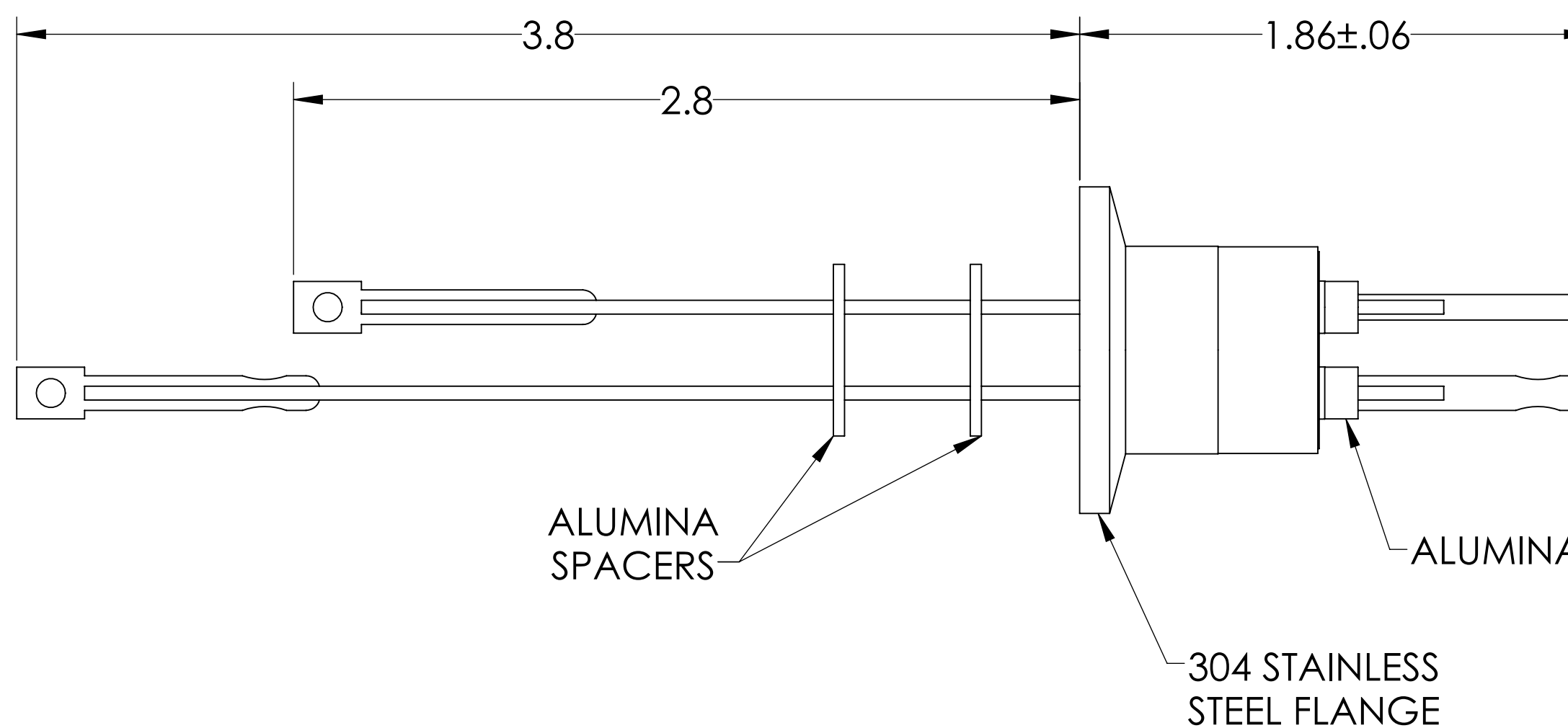

PART #	T/C TYPE
A0392-1-QF	J
A0392-2-QF	K
A0392-3-QF	C
A0392-4-QF	E

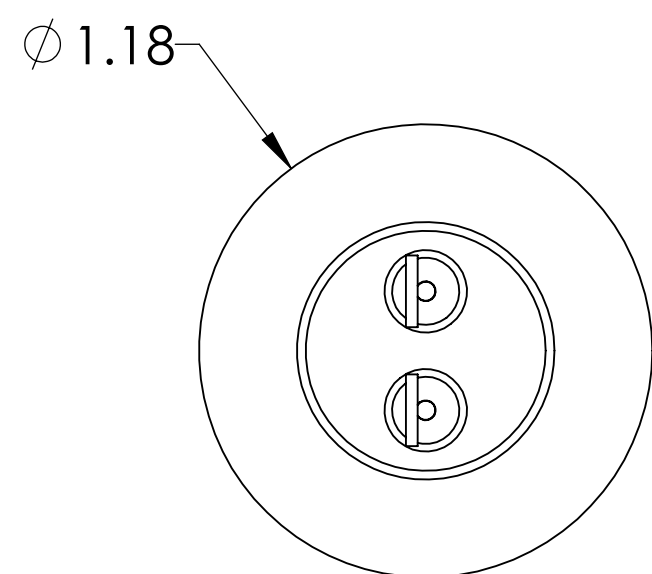
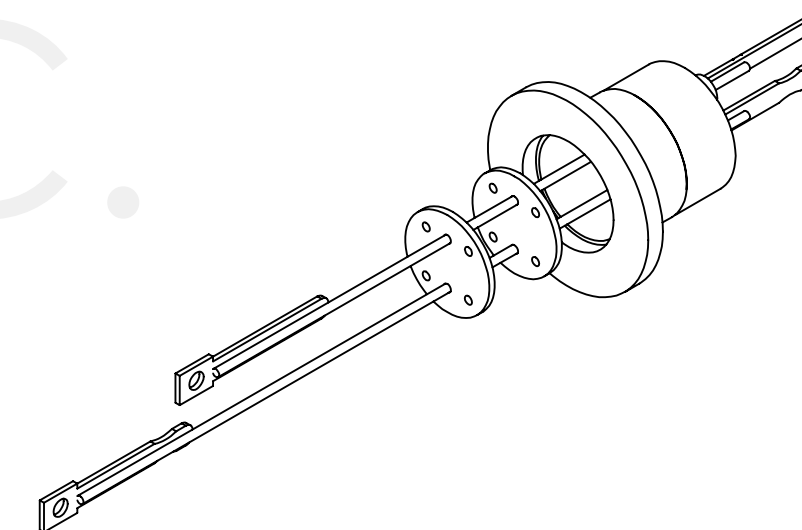
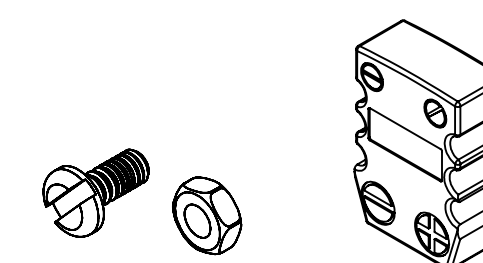

**SPECIFICATIONS:**

1. TEMPERATURE RATING: -100 TO 450°C
2. LEAK RATE < 1X10-9 ATM CC/SEC HE

Thermocouple Feedthrough, 1 Pair, Miniature Connector, 1.18" QF/KF

UNLESS OTHERWISE SPECIFIED:	QUOTATION #	N/A
DIMENSIONS ARE IN INCHES TOLERANCES:	NAME	DATE
ANGULAR: MACH ± 1/2°	WJ	9/11/2015
TWO PLACE DECIMAL ± .030	CHECKED	9/11/2015
THREE PLACE DECIMAL ± .015	ENG APPR.	WJ 9/11/2015
MATERIAL	THIRD ANGLE:	
	APPLICATION	
	NEXT ASSY	USED ON
FINISH	SURFACE FINISH:	63/ OR BETTER
PLATING	UNLESS OTHERWISE SPECIFIED:	
	ALL DIAMETERS CONCENTRIC WITHIN .005. REMOVE ALL BURRS AND SHARP EDGES	
	TITLE:	MPF PRODUCTS INC.
	THERMOCOUPLE, 1 PAIR, CONNECTOR, 1.18" QF/KF	
	DOWNLOADED FROM MPFPI.COM	
	DWG. NO.	A0392
	REV	
	Friday, February 8, 2019 8:54:42 AM	