

MPF PRODUCTS INC.

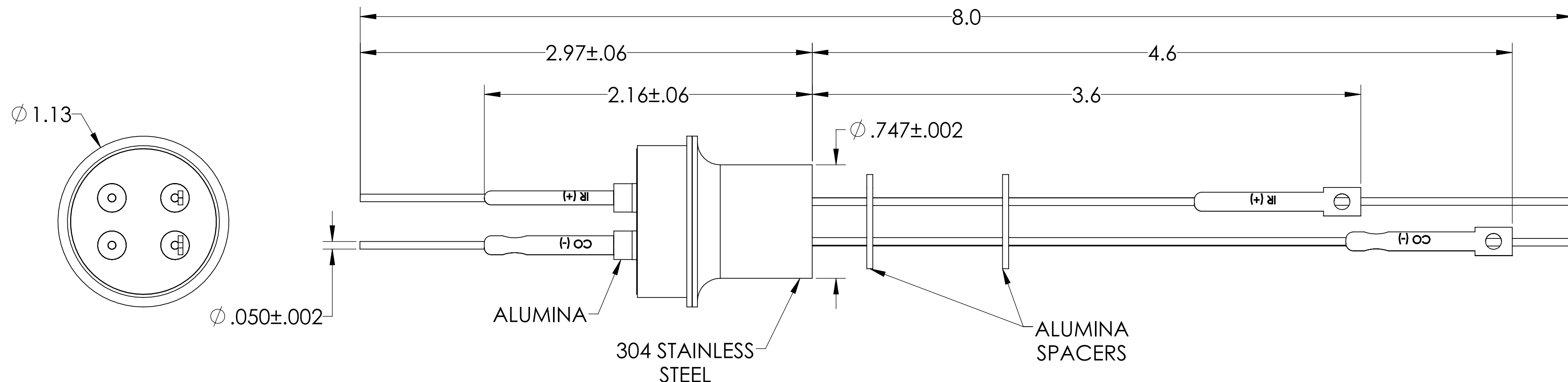

PART #	T/C TYPE	POWER LEADS	CURRENT RATINGS (POWER PINS ONLY)
A0434-1-W	K	COPPER	25 AMPS (PER PIN)
A0434-2-W	K	NICKEL	8 AMPS (PER PIN)
A0434-3-W	J	COPPER	25 AMPS (PER PIN)
A0434-4-W	J	NICKEL	8 AMPS (PER PIN)
A0434-5-W	C	COPPER	25 AMPS (PER PIN)
A0434-6-W	C	NICKEL	8 AMPS (PER PIN)
A0434-7-W	E	COPPER	25 AMPS (PER PIN)
A0434-8-W	E	NICKEL	8 AMPS (PER PIN)

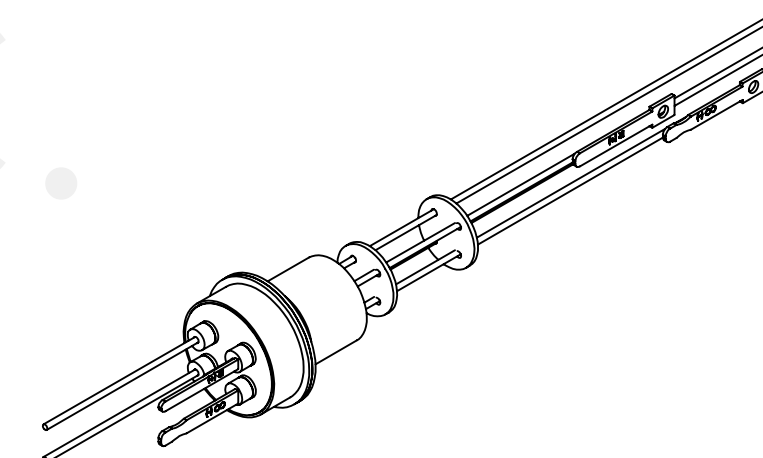
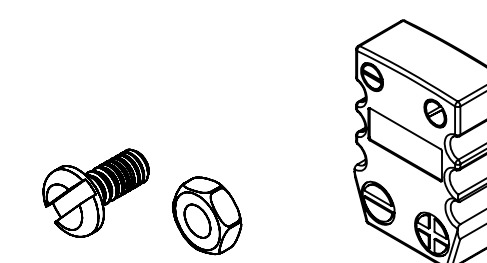

SPECIFICATIONS:

- VOLTAGE: 1000 VOLTS DC
- CURRENT: SEE TABLE
- TEMPERATURE RATING: -100 TO 450°C
- LEAK RATE < 1X10-9 ATM CC/SEC HE

Thermocouple-Power Feedthrough, 1 Pair , w/ Miniature TC Connector, 1000 Volts, 2 Pins, 0.75" Dia Stainless Steel Weld Adapter

UNLESS OTHERWISE SPECIFIED:	QUOTATION #	N/A
DIMENSIONS ARE IN INCHES TOLERANCES:	NAME	DATE
ANGULAR: MACH ± 1/2°	DRAWN	9/11/2015
TWO PLACE DECIMAL ± .030	CHECKED	9/11/2015
THREE PLACE DECIMAL ± .015	ENG APPR.	WJ 9/11/2015
MATERIAL	THIRD ANGLE:	
FINISH	APPLICATION	
PLATING	NEXT ASSY	USED ON
	SURFACE FINISH:	63/ OR BETTER
	UNLESS OTHERWISE SPECIFIED:	
	ALL DIAMETERS CONCENTRIC WITHIN .005. REMOVE ALL BURRS AND SHARP EDGES	
	TITLE:	MPF PRODUCTS INC.
		THERMOCOUPLE-POWER, 1 PAIR, 1000V, 2 PINS, .747" WELD ADAPTER
	DOWNLOADED FROM MPFPI.COM	
	DWG. NO.	A0434
	REV	
	Monday, February 11, 2019 7:35:22 AM	