

MPF PRODUCTS INC.

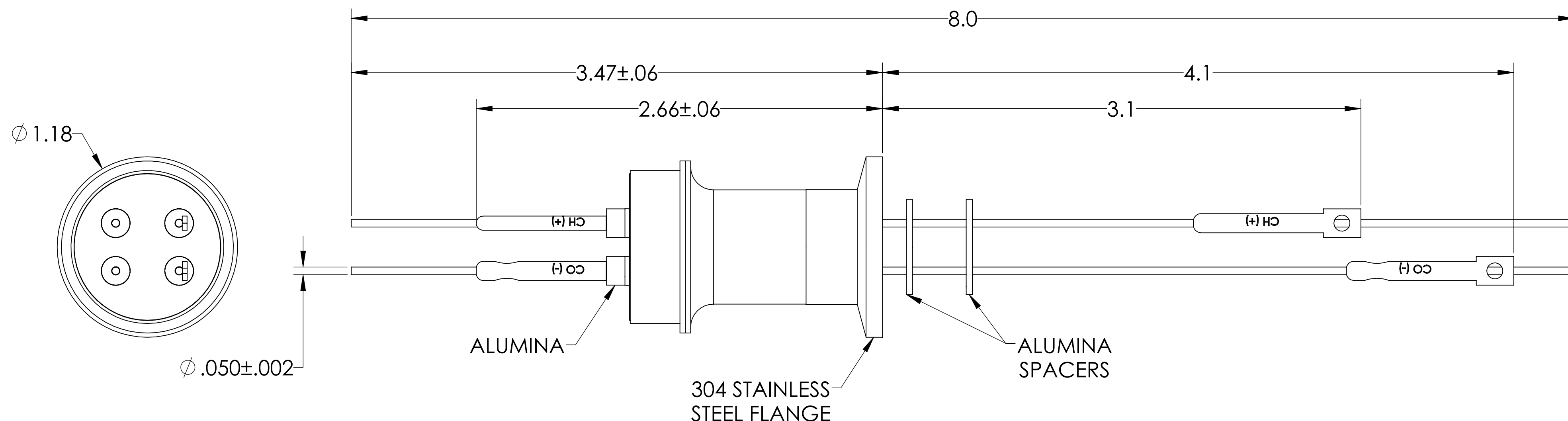
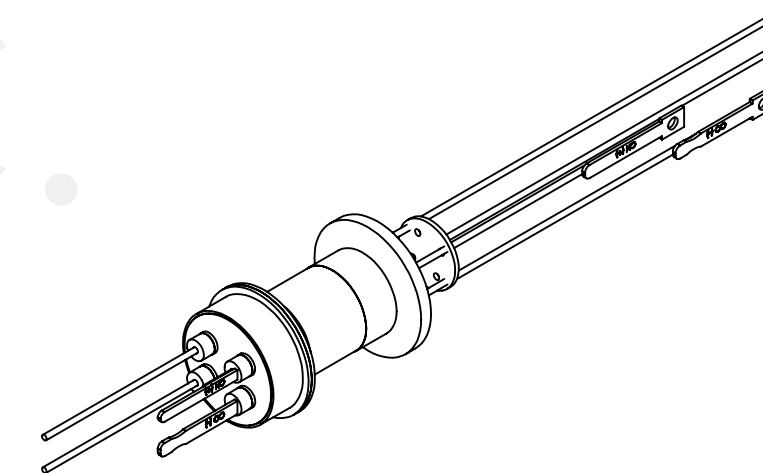

PART #	T/C TYPE	POWER LEADS	CURRENT RATINGS (POWER PINS ONLY)
A0435-1-QF	K	COPPER	15 AMPS (PER PIN)
A0435-2-QF	K	NICKEL	5 AMPS (PER PIN)
A0435-3-QF	J	COPPER	15 AMPS (PER PIN)
A0435-4-QF	J	NICKEL	5 AMPS (PER PIN)
A0435-5-QF	C	COPPER	15 AMPS (PER PIN)
A0435-6-QF	C	NICKEL	5 AMPS (PER PIN)
A0435-7-QF	E	COPPER	15 AMPS (PER PIN)
A0435-8-QF	E	NICKEL	5 AMPS (PER PIN)

SPECIFICATIONS:

- VOLTAGE: 1000 VOLTS DC
- CURRENT: SEE TABLE
- TEMPERATURE RATING: -100 TO 450°C
- LEAK RATE < 1X10-9 ATM CC/SEC HE

Thermocouple-Power Feedthrough, 1 Pair , w/ Miniature TC Connector, 1000 Volts, 2 Pins, 1.18" QF/KF

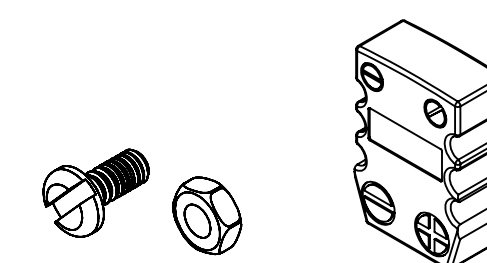

UNLESS OTHERWISE SPECIFIED:		QUOTATION #		N/A	
DIMENSIONS ARE IN INCHES TOLERANCES:		NAME	DATE	MPF PRODUCTS INC.	
ANGULAR: MACH ± 1/2°		DRAWN	9/11/2015	TITLE:	
TWO PLACE DECIMAL ± .030		CHECKED	9/11/2015	THERMOCOUPLE-POWER,	
THREE PLACE DECIMAL ± .015		ENG APPR.	9/11/2015	1 PAIR, 1000V, 2 PINS,	
MATERIAL		THIRD ANGLE:		1.18" QF/KF	
FINISH		APPLICATION		DOWNLOADED FROM MPFPI.COM	
PLATING		NEXT ASSY		DWG. NO.	
SURFACE FINISH: 63/ OR BETTER		USED ON		REV	
UNLESS OTHERWISE SPECIFIED:		ALL DIAMETERS CONCENTRIC WITHIN .005. REMOVE ALL BURRS AND SHARP EDGES		A0435	
		Friday, February 8, 2019 8:42:13 AM			