

MPF PRODUCTS INC.

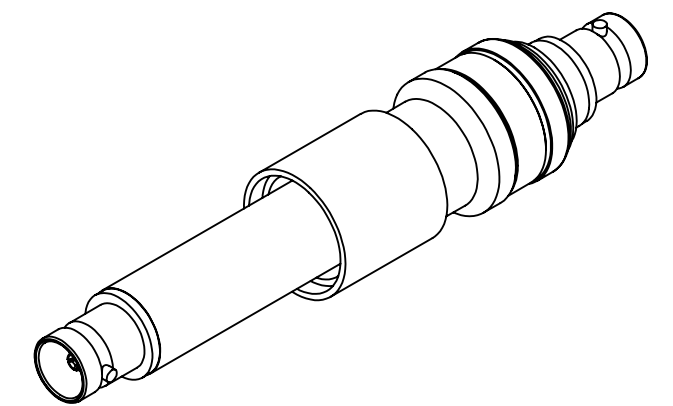

PART #	AIRSIDE CONNECTOR INCLUDED
A0466-2-W	YES
A0466-5-W	NO

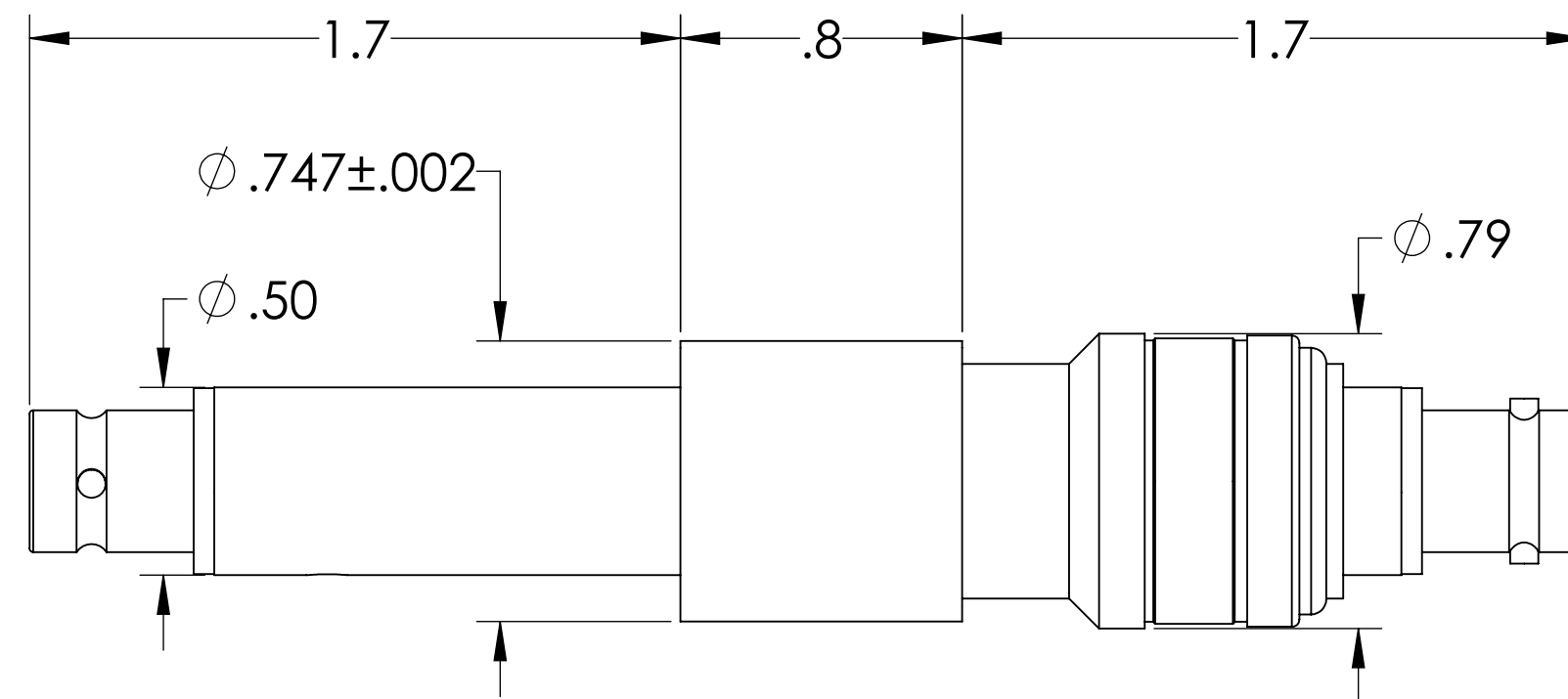
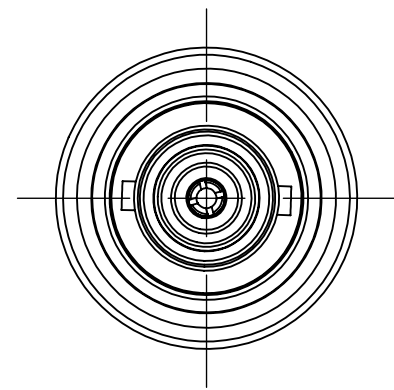
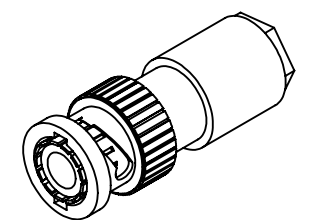

NOTE:

1. SHIELD: FLOATING
2. VOLTAGE: 2500 VOLTS DC SHIELD TO GROUND, 5000V PIN TO SHEILD
3. CURRENT: 3 AMPS
4. TEMPERATURE RATING: -200 TO 450°C (FEEDTHROUGH), 65 TO 165°C (AIRSIDE CONNECTOR)
5. IMPEDANCE: NON-CONSTANT

MHV Coaxial Feedthrough, 1 Pin, Floating Shield, Double Ended, 0.747" Dia SS Weld Adapter, UHV Compatible

UNLESS OTHERWISE SPECIFIED:		QUOTATION #		N/A	
DIMENSIONS ARE IN INCHES TOLERANCES:		NAME	DATE	MPF PRODUCTS INC.	
ANGULAR: MACH ± 1/2°		WJ	9/11/2015		
TWO PLACE DECIMAL ± .030		CHECKED	9/11/2015		
THREE PLACE DECIMAL ± .015		ENG APPR.	WJ 9/11/2015		
MATERIAL		THIRD ANGLE:		TITLE: MHV COAXIAL FEEDTHROUGH, 1 PIN, FLOATING SHIELD, DOUBLE ENDED, 0.747" DIA SS WELD ADAPTER	
		APPLICATION NEXT ASSY USED ON			
FINISH		SURFACE FINISH: 63 OR BETTER		DWG. NO.	
PLATING		UNLESS OTHERWISE SPECIFIED: ALL DIAMETERS CONCENTRIC WITHIN .005. REMOVE ALL BURRS AND SHARP EDGES		A0466 MHV	
		Friday, January 18, 2019 8:09:58 AM		REV	