

MPF PRODUCTS INC.

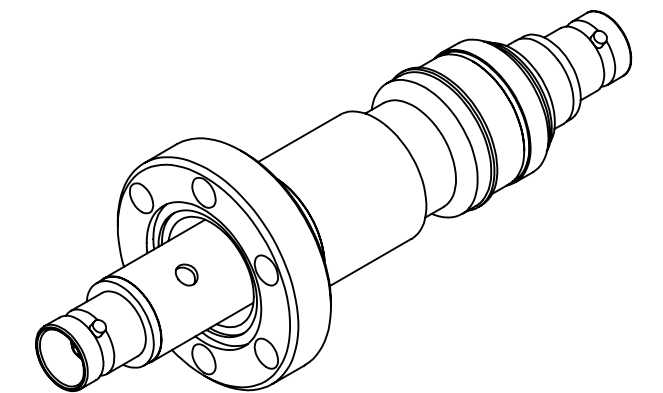
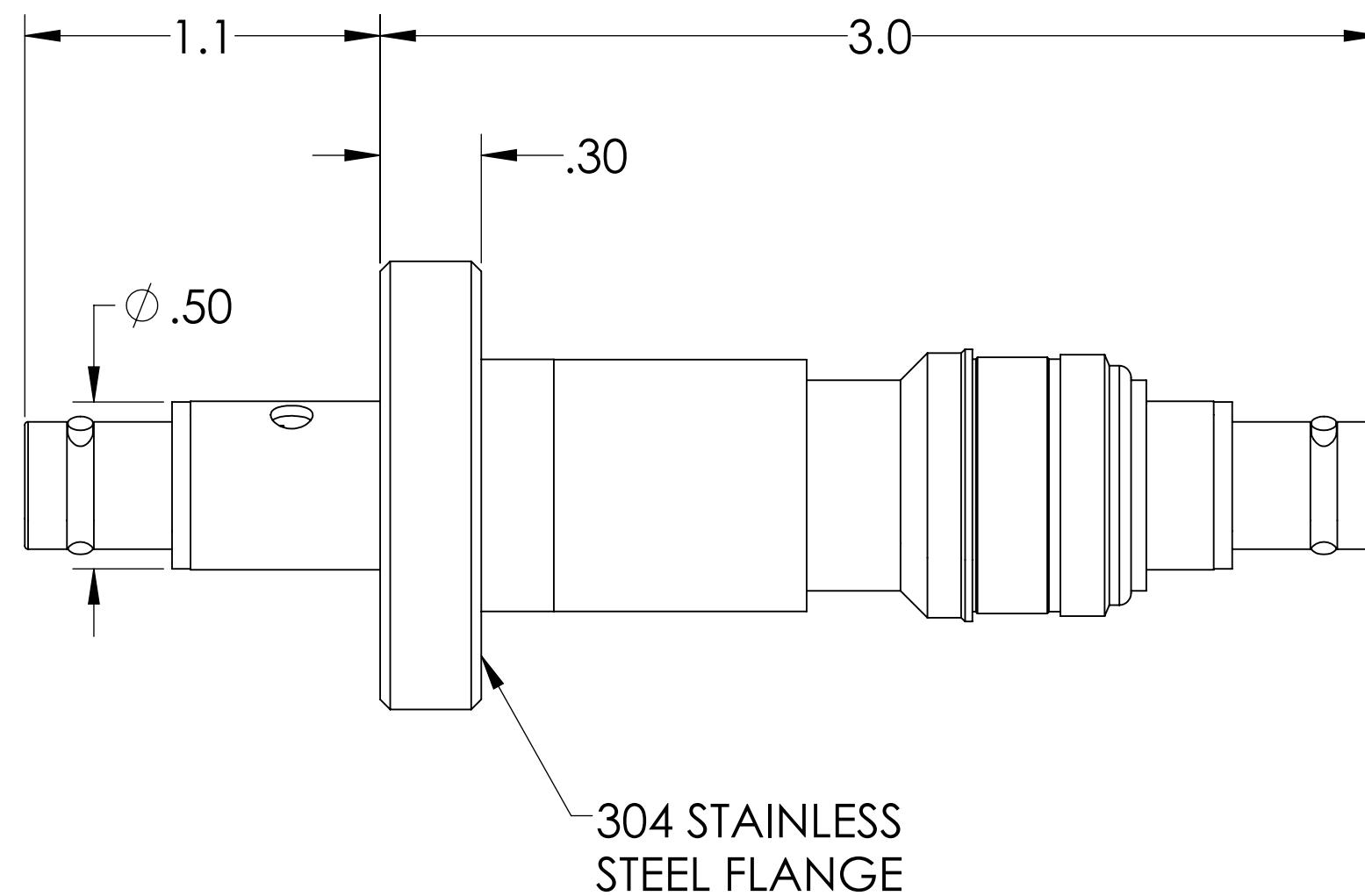
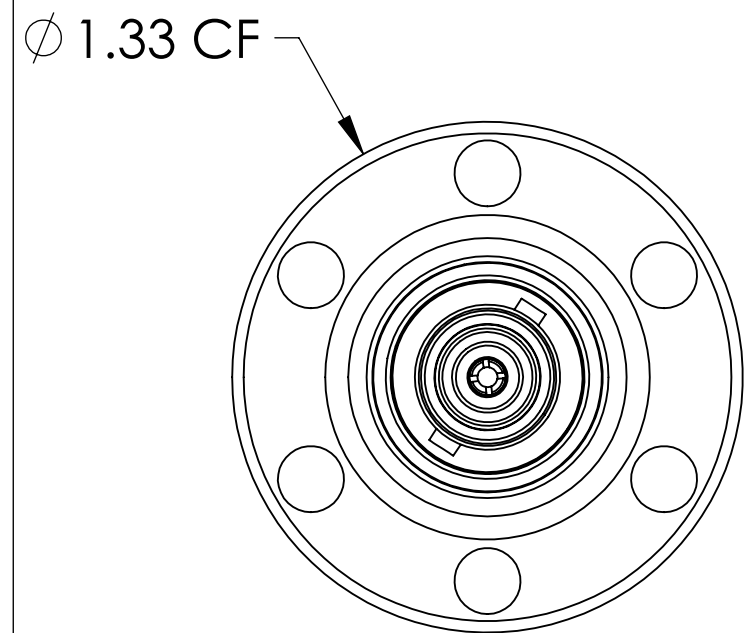

PART #	AIRSIDE CONNECTOR INCLUDED
A0474-1-CF	YES
A0474-3-CF	NO

NOTE:

1. SHIELD: FLOATING
2. VOLTAGE: 2500 VOLTS DC SHIELD TO GROUND, 500V PIN TO SHEILD
3. CURRENT: 3 AMPS
4. TEMPERATURE RATING: -200 TO 450°C (FEEDTHROUGH), 65 TO 165°C (AIRSIDE CONNECTOR)
5. IMPEDANCE: NON-CONSTANT

BNC Coaxial Feedthrough, 1 Pin, Floating Shield, Double Ended, 1.33" Conflat Flange, UHV Compatible

UNLESS OTHERWISE SPECIFIED:		QUOTATION #		N/A	
DIMENSIONS ARE IN INCHES TOLERANCES:		NAME	DATE	MPF PRODUCTS INC.	
ANGULAR: MACH ± 1/2°		DRAWN	9/11/2015		
TWO PLACE DECIMAL ± .030		CHECKED	9/11/2015		
THREE PLACE DECIMAL ± .015		ENG APPR.	9/11/2015		
MATERIAL		THIRD ANGLE:		TITLE: BNC COAXIAL FEEDTHROUGH, 1 PIN, FLOATING SHIELD, DOUBLE ENDED, 1.33" CONFLAT FLANGE	
FINISH					
PLATING		APPLICATION: NEXT ASSY USED ON			
SURFACE FINISH:		63/ OR BETTER		DWG. NO. REV	
UNLESS OTHERWISE SPECIFIED:		ALL DIAMETERS CONCENTRIC WITHIN .005. REMOVE ALL BURRS AND SHARP EDGES		A0474 BNC	
		Friday, January 18, 2019 8:07:46 AM		DOWNLOADED FROM MPFPI.COM	