

MPF PRODUCTS INC.

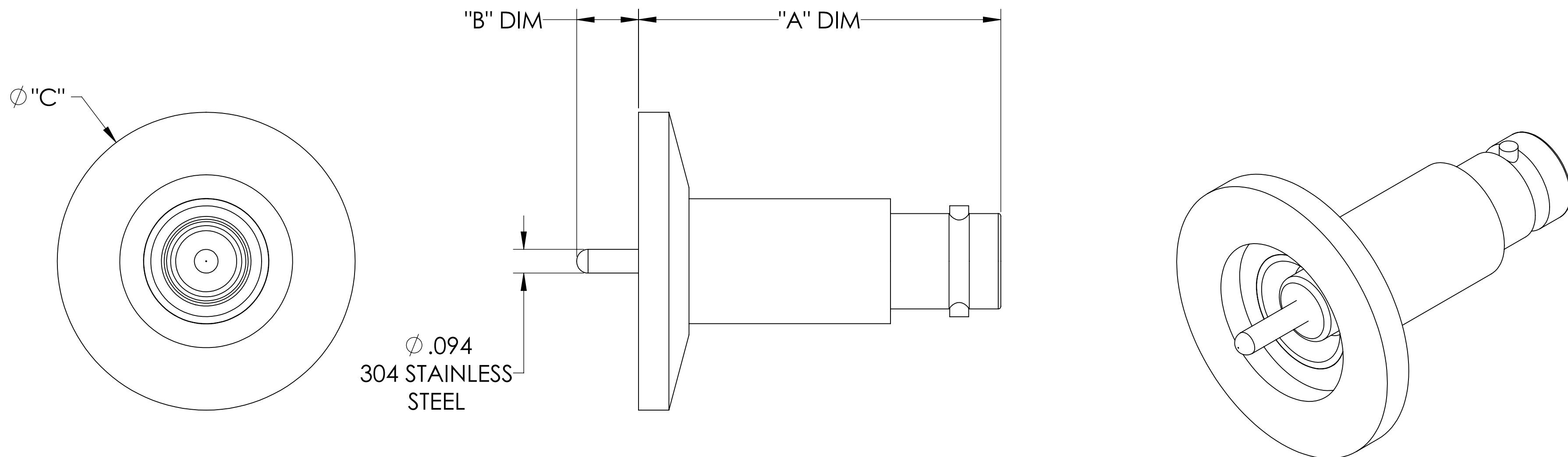

PART #	"A" DIM	"B" DIM	Ø "C"	B.C.	FEEDTHROUGH QTY.	AIRSIDE CONNECTOR INCLUDED
A0477-1-QF	1.43	.30	1.18	OMIT	1	YES
A0477-2-QF	1.33	.40	2.16	OMIT	1	YES
A0477-3-QF	1.33	.40	2.16	.75	2	YES
A0477-4-QF	1.33	.40	2.95	.95	3	YES
A0477-5-QF	1.33	.40	2.95	.95	4	YES

NOTE:

1. SHIELD: GROUNDED
2. VOLTAGE: 5000 VOLTS DC
3. CURRENT: 3 AMPS
4. TEMPERATURE RATING: -200 TO 450°C (FEEDTHROUGH), 65 TO 165°C (AIRSIDE CONNECTOR)
5. IMPEDANCE: NON-CONSTANT

MHV Coaxial Feedthrough, 1/2/3/4 Pin, Grounded Shield, QF/KF, UHV Compatible

UNLESS OTHERWISE SPECIFIED:		QUOTATION #	
DIMENSIONS ARE IN INCHES		N/A	
TOLERANCES:		NAME	DATE
ANGULAR: MACH ± 1/2°		WJ	9/11/2015
TWO PLACE DECIMAL ± .030		CHECKED	9/11/2015
THREE PLACE DECIMAL ± .015		ENG APPR.	WJ 9/11/2015
MATERIAL		THIRD ANGLE:	
APPLICATION			
NEXT ASSY		USED ON	
FINISH	SURFACE FINISH: 63 OR BETTER	TITLE:	
PLATING	UNLESS OTHERWISE SPECIFIED:	MPF PRODUCTS INC.	
ALL DIAMETERS CONCENTRIC WITHIN .005. REMOVE ALL BURRS AND SHARP EDGES		MHV COAXIAL FEEDTHROUGH, 1/2/3/4 PIN, GROUNDED SHIELD, QF/KF	
		DOWNLOADED FROM MPFPI.COM	
		DWG. NO.	REV
		A0477	
		Thursday, January 17, 2019 3:23:47 PM	