

# MPF PRODUCTS INC.

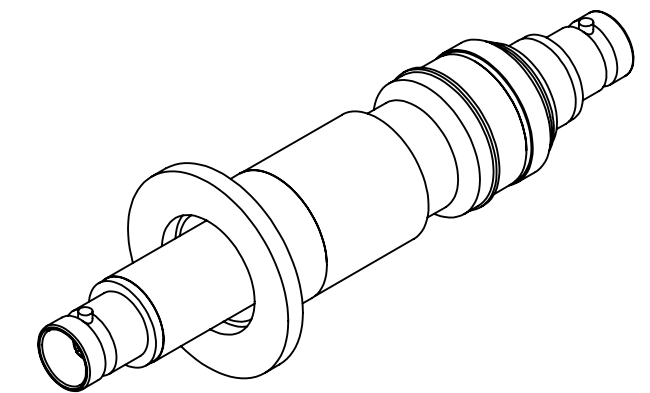
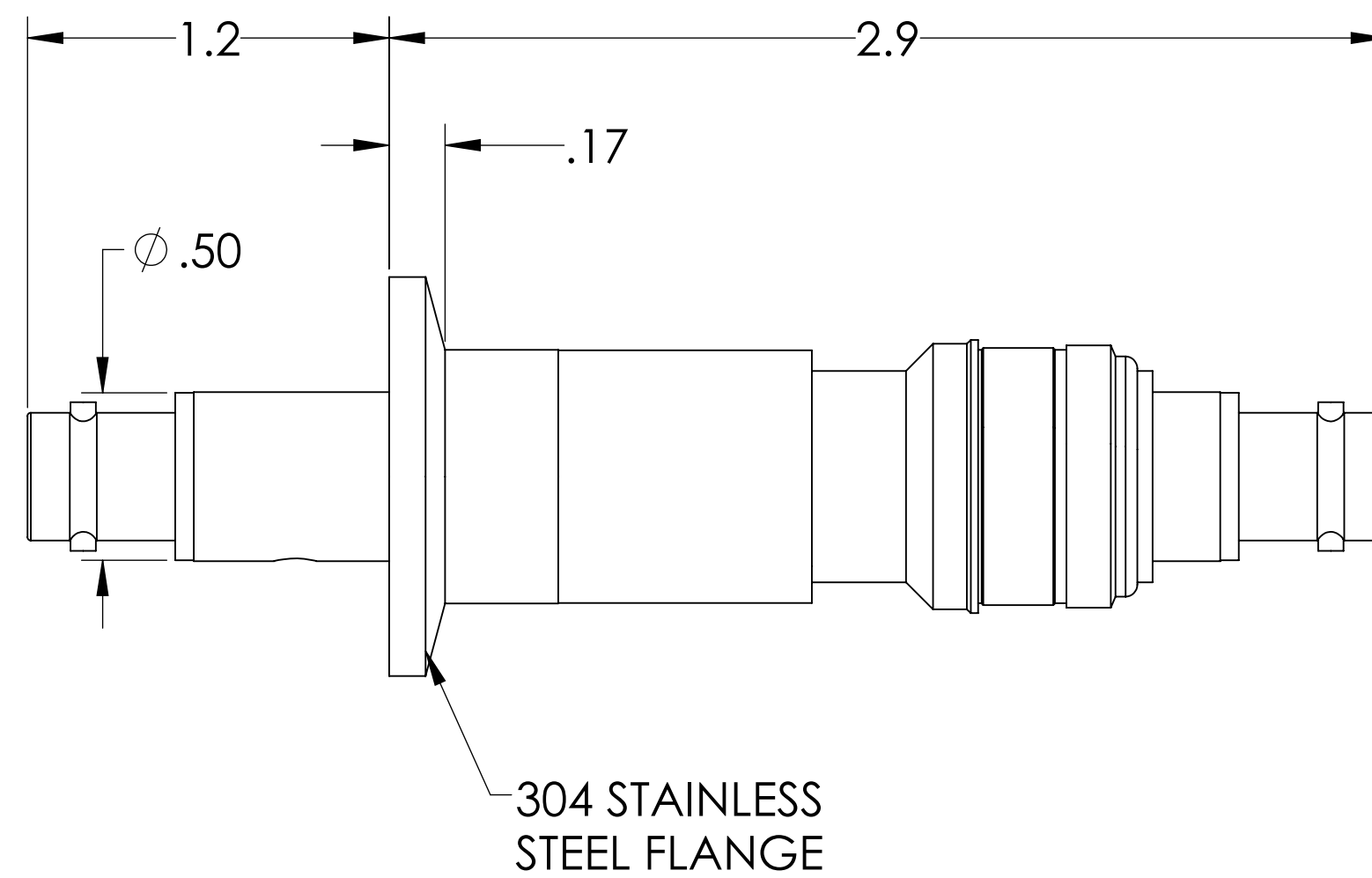
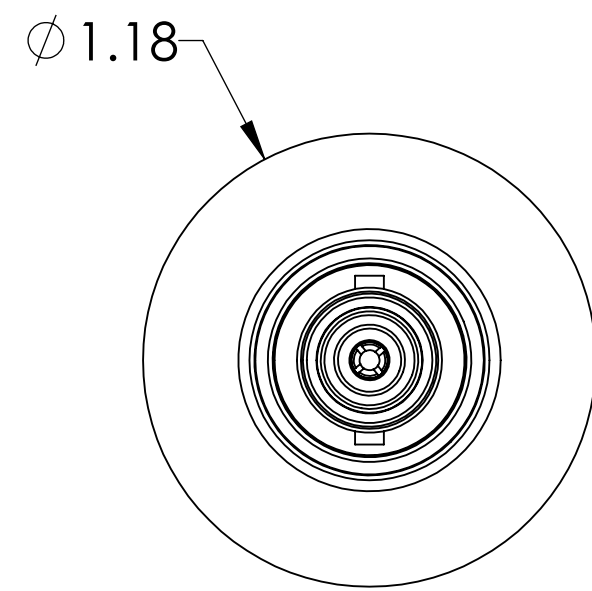

PART #	AIRSIDE CONNECTOR INCLUDED
A0480-1-QF	YES
A0480-4-QF	NO

**NOTE:**

1. SHIELD: FLOATING
2. VOLTAGE: 2500 VOLTS DC SHIELD TO GROUND, 500V PIN TO SHEILD
3. CURRENT: 3 AMPS
4. TEMPERATURE RATING: -200 TO 450°C (FEEDTHROUGH), 65 TO 165°C ( AIRSIDE CONNECTOR)
5. IMPEDANCE: NON-CONSTANT

BNC Coaxial Feedthrough, 1 Pin, Floating Shield, Double Ended, 1.18" QF/KF, UHV Compatible

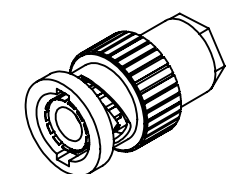

UNLESS OTHERWISE SPECIFIED:	QUOTATION #	N/A	
DIMENSIONS ARE IN INCHES TOLERANCES:	DRAWN	NAME	DATE
ANGULAR: MACH ± 1/2°	WJ	WJ	9/11/2015
TWO PLACE DECIMAL ± .030	CHECKED		9/11/2015
THREE PLACE DECIMAL ± .015	ENG APPR.	WJ	9/11/2015
MATERIAL	THIRD ANGLE:		
FINISH	APPLICATION		
PLATING	SURFACE FINISH:	63/ OR BETTER	
	UNLESS OTHERWISE SPECIFIED:	ALL DIAMETERS CONCENTRIC WITHIN .005. REMOVE ALL BURRS AND SHARP EDGES	
	QUOTATION #	N/A	
	DWG. NO.	A0480 BNC	
	TITLE:	BNC COAXIAL FEEDTHROUGH, 1 PIN, FLOATING SHIELD, DOUBLE ENDED, 1.18" QF/KF	
	REV		
	DATE:	Thursday, October 31, 2019 2:59:18 PM	