

MPF PRODUCTS INC.

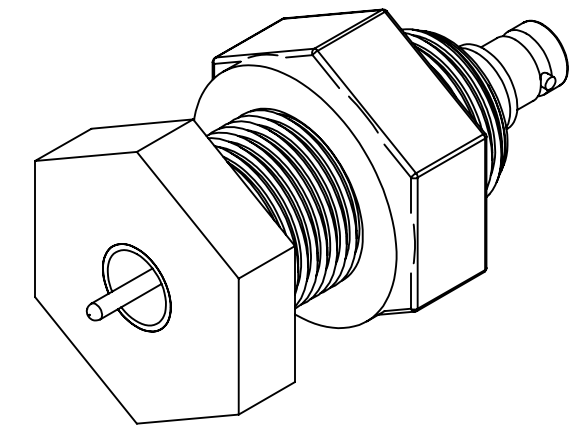
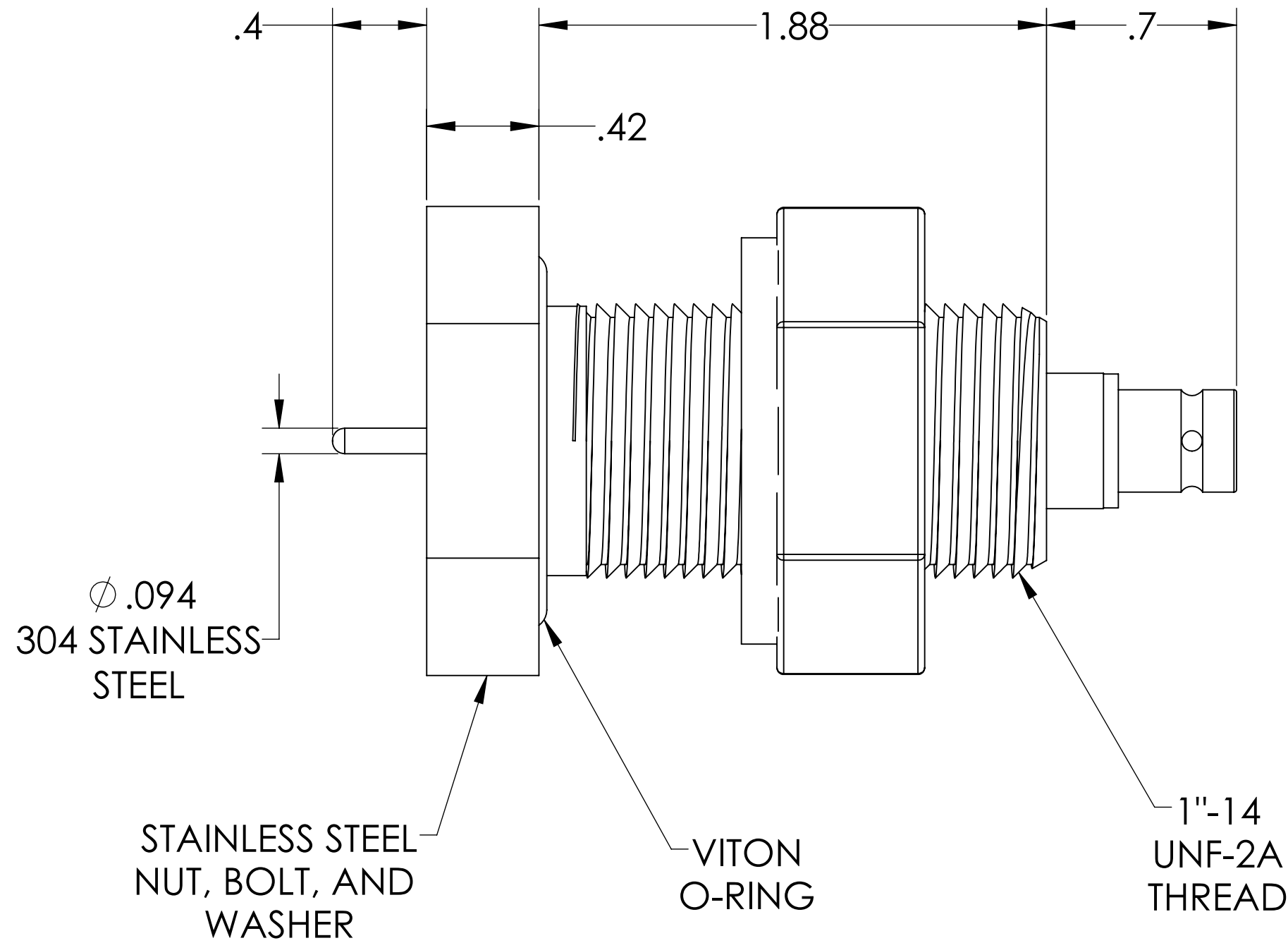
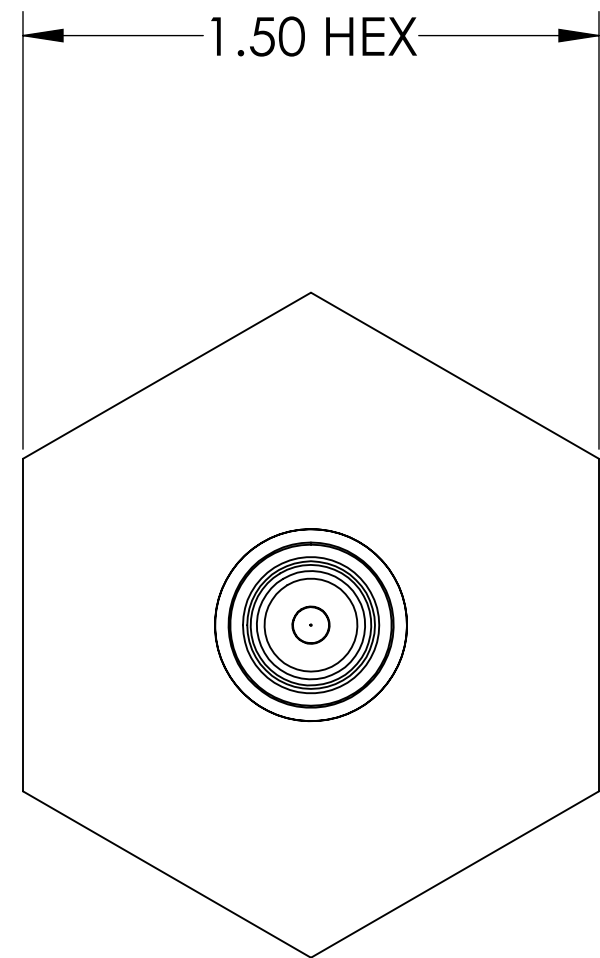

PART #	AIRSIDE CONNECTOR INCLUDED
A0482-2-BP	YES
A0482-5-BP	NO

NOTE:

1. SHIELD: GROUNDED
2. VOLTAGE: 500 VOLTS DC
3. CURRENT: 3 AMPS
4. TEMPERATURE RATING: -200 TO 450°C (FEEDTHROUGH), 65 TO 165°C (AIRSIDE CONNECTOR)
5. IMPEDANCE: NON-CONSTANT

BNC Coaxial Feedthrough, 1 Pin, Grounded Shield, 1" Baseplate Bolt, UHV Compatible

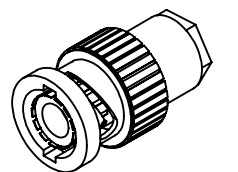

UNLESS OTHERWISE SPECIFIED:		QUOTATION #		N/A	
DIMENSIONS ARE IN INCHES TOLERANCES:		NAME	DATE	MPF PRODUCTS INC.	
ANGULAR: MACH ± 1/2°		DRAWN	9/11/2015		
TWO PLACE DECIMAL ± .030		CHECKED	9/11/2015		
THREE PLACE DECIMAL ± .015		ENG APPR.	9/11/2015		
MATERIAL		THIRD ANGLE:		TITLE: BNC COAXIAL FEEDTHROUGH, 1 PIN, GROUNDED SHIELD, 1" BASEPLATE BOLT	
FINISH		APPLICATION			
PLATING		NEXT ASSY USED ON			
SURFACE FINISH: 63 OR BETTER		UNLESS OTHERWISE SPECIFIED:			
ALL DIAMETERS CONCENTRIC WITHIN .005. REMOVE ALL BURRS AND SHARP EDGES		DWG. NO.		REV	
		A0482 BNC		Friday, January 18, 2019 8:58:59 AM	