

MPF PRODUCTS INC.

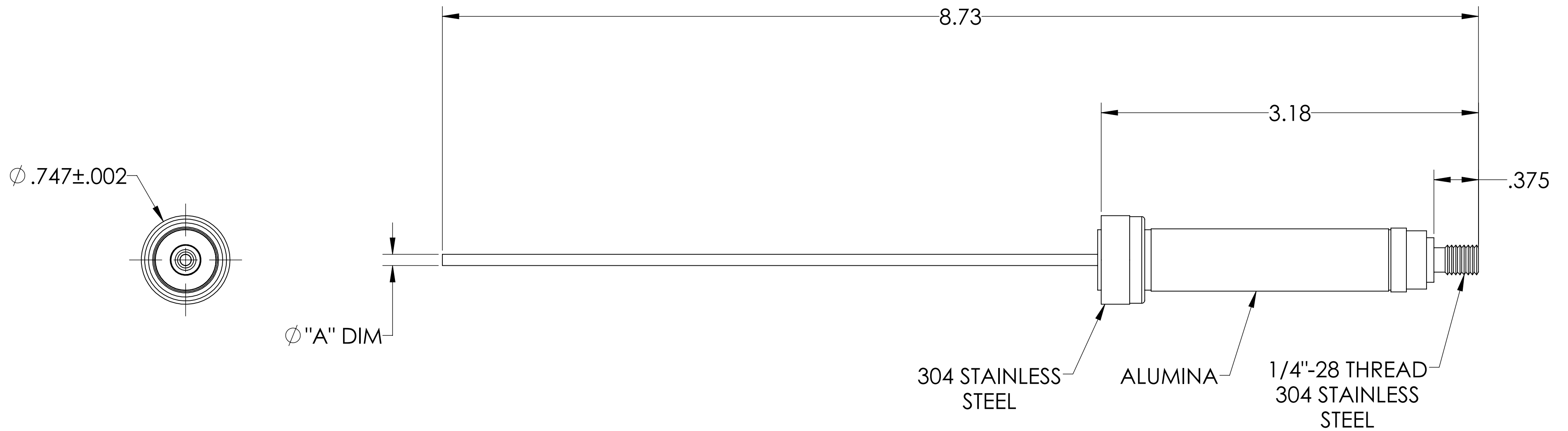
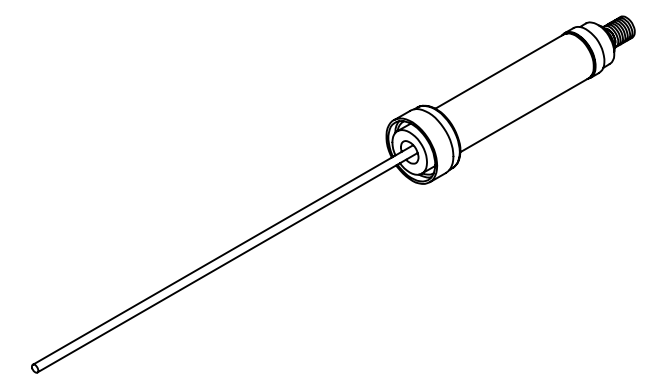

PART #	Ø "A" DIM	CONDUCTOR MATERIAL	CURRENT RATING
A0531-1-W	.092	NICKEL 200	15 AMPS
A0531-2-W	.094	OFHC COPPER	50 AMPS
A0531-3-W	.094	304 STN STL	3 AMPS

- NOTE:
1. VOLTAGE: 20,000 VOLTS DC
 2. CURRENT: SEE TABLE
 3. TEMPERATURE RATING: -100 TO 450°C

Power Feedthrough, 20 KV, 1 Pin, 0.747" Stainless Steel Weld Adapter, UHV Rated, Bakeable to 450°C

UNLESS OTHERWISE SPECIFIED:	QUOTATION #	N/A
DIMENSIONS ARE IN INCHES TOLERANCES:	NAME	DATE
ANGULAR: MACH ± 1/2°	WJ	9/11/2015
TWO PLACE DECIMAL ± .030	CHECKED	9/11/2015
THREE PLACE DECIMAL ± .015	ENG APPR.	WJ 9/11/2015
MATERIAL	THIRD ANGLE:	
FINISH	APPLICATION	
PLATING	NEXT ASSY USED ON	
	SURFACE FINISH:	63 OR BETTER
	UNLESS OTHERWISE SPECIFIED:	
	ALL DIAMETERS CONCENTRIC WITHIN .005. REMOVE ALL BURRS AND SHARP EDGES	
TITLE:		MPF PRODUCTS INC.
TITLE:		POWER FEEDTHROUGH, 20 KV, 1 PIN, 0.747" WELD ADAPTER
DOWNLOADED FROM MPFPI.COM		
DWG. NO.	A0531	REV
Thursday, December 6, 2018 11:43:39 AM		