

# MPF PRODUCTS INC.

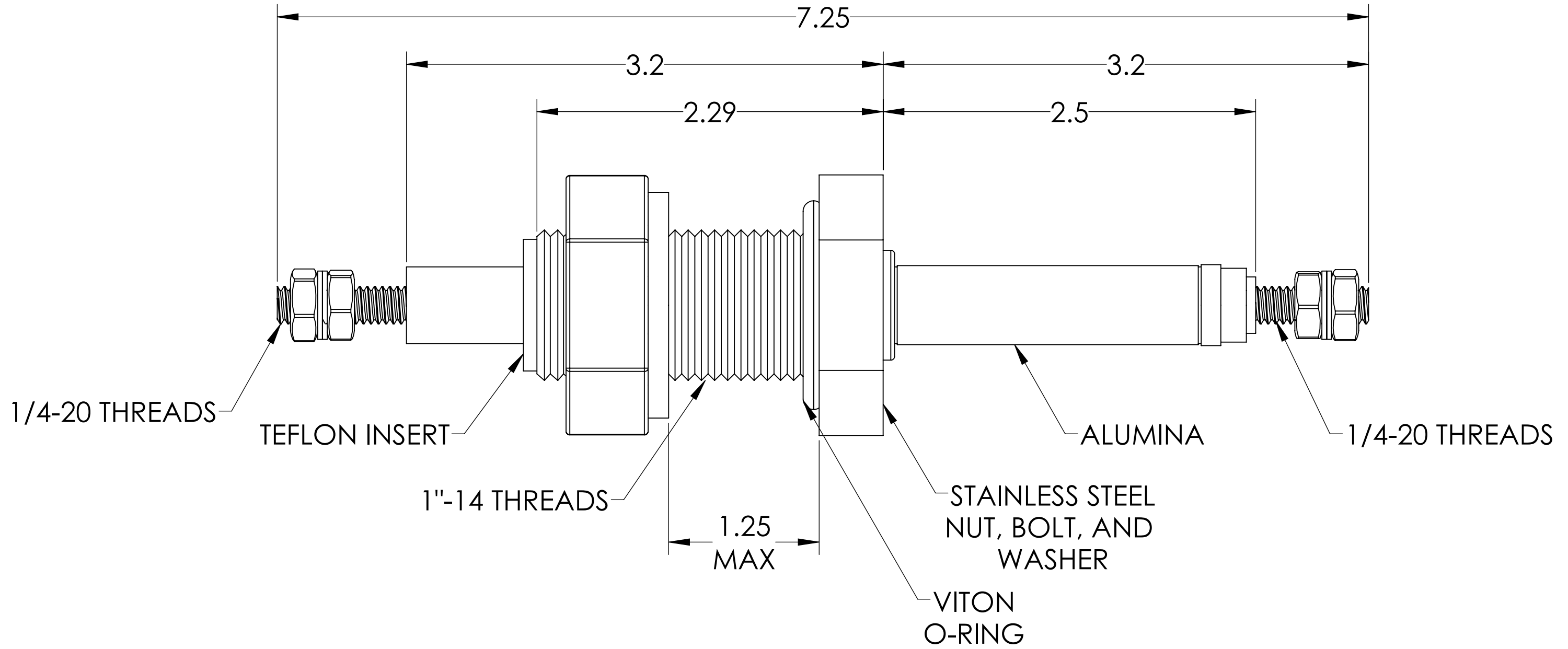
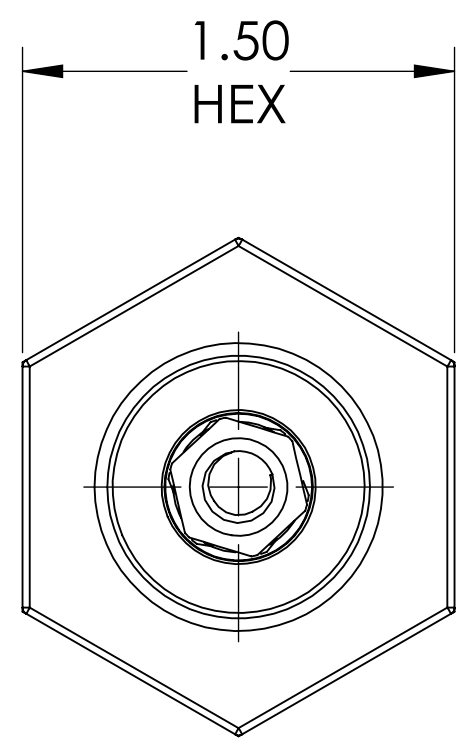
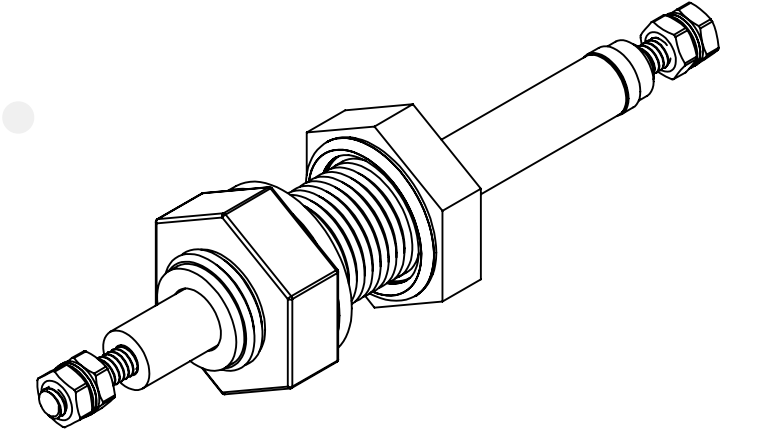

PART #	CONDUCTOR MATERIAL	CURRENT RATING
A0544-1-BP	OFHC COPPER	180 AMPS
A0544-2-BP	NICKEL 200	55 AMPS
A0544-3-BP	304 STN STL	7 AMPS

- NOTE:
1. VOLTAGE: 12,000 VOLTS DC
  2. CURRENT: SEE TABLE
  3. TEMPERATURE RATING: -100 TO 450°C

Power Feedthrough, 12 KV, 1 Pins, 1" Baseplate Bolt, UHV Rated, Bakeable to 450°C

UNLESS OTHERWISE SPECIFIED:		QUOTATION #		N/A	
DIMENSIONS ARE IN INCHES TOLERANCES:		NAME	DATE	MPF PRODUCTS INC.	
ANGULAR: MACH ± 1/2°		DRAWN	9/11/2015		
TWO PLACE DECIMAL ± .030		CHECKED	9/11/2015		
THREE PLACE DECIMAL ± .015		ENG APPR.	9/11/2015		
MATERIAL		THIRD ANGLE:		POWER FEEDTHROUGH, 12 KV, 1 PIN, 1" BASEPLATE	
FINISH		APPLICATION			
PLATING		NEXT ASSY USED ON			
SURFACE FINISH: 63 OR BETTER		UNLESS OTHERWISE SPECIFIED:		DOWNLOADED FROM MPFPI.COM	
ALL DIAMETERS CONCENTRIC WITHIN .005. REMOVE ALL BURRS AND SHARP EDGES		DWG. NO.		REV	
		A0544		A0544	
		Tuesday, January 22, 2019 10:49:40 AM			