

MPF PRODUCTS INC.

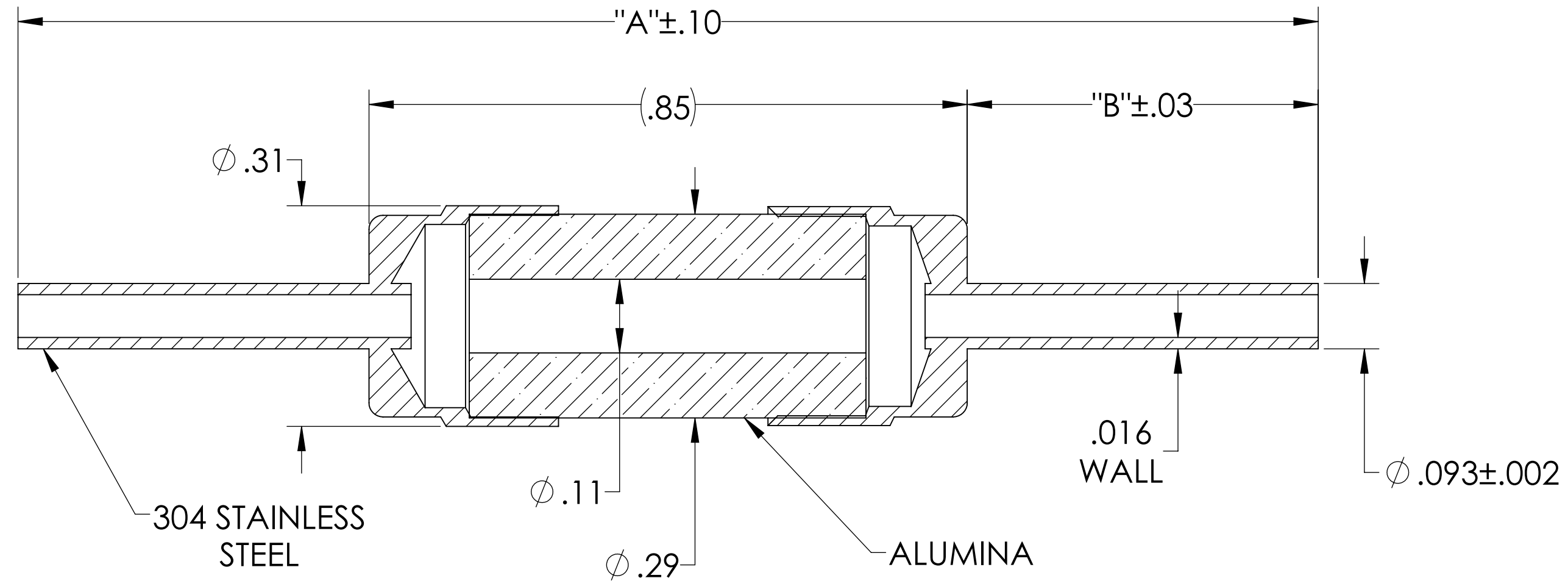
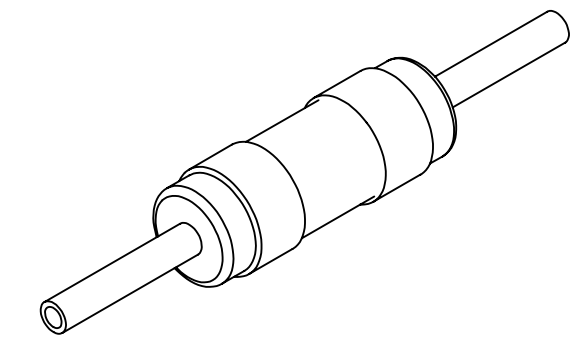

PART #	"A" ± .10	"B" ± .03
A0574-1-W	1.80	.475
A0574-2-W	2.30	.725

SPECIFICATIONS:

1. VOLTAGE: 5KV
2. TEMPERATURE: -200°C TO 450°C
3. LEAK RATE < 1X10-9 ATM CC/SEC HE

Break, 5KV Isolation, 0.093" Dia Stainless Steel Tube Adapters, High Voltage Isolation, Thermal Isolation, Weldable Tube Ends, UHV Compatible

UNLESS OTHERWISE SPECIFIED:		QUOTATION #		N/A	
DIMENSIONS ARE IN INCHES		NAME	DATE	MPF PRODUCTS INC.	
TOLERANCES:		DRAWN	9/11/2015		
ANGULAR: MACH ± 1/2°		CHECKED	9/11/2015		
TWO PLACE DECIMAL ± .030		ENG APPR.	9/11/2015		
THREE PLACE DECIMAL ± .015		THIRD ANGLE:		TITLE: BREAK, 5KV ISOLATION, 0.093" DIA STAINLESS STEEL TUBE ADAPTERS DWG. NO. A0574 Monday, October 7, 2019 10:43:38 AM	
MATERIAL					
FINISH		APPLICATION: NEXT ASSY: USED ON:			
PLATING		SURFACE FINISH: 63 OR BETTER		DOWNLOADED FROM MPFPI.COM	
		UNLESS OTHERWISE SPECIFIED:		REV	
		ALL DIAMETERS CONCENTRIC WITHIN .005. REMOVE ALL BURRS AND SHARP EDGES		A0574	