

MPF PRODUCTS INC.

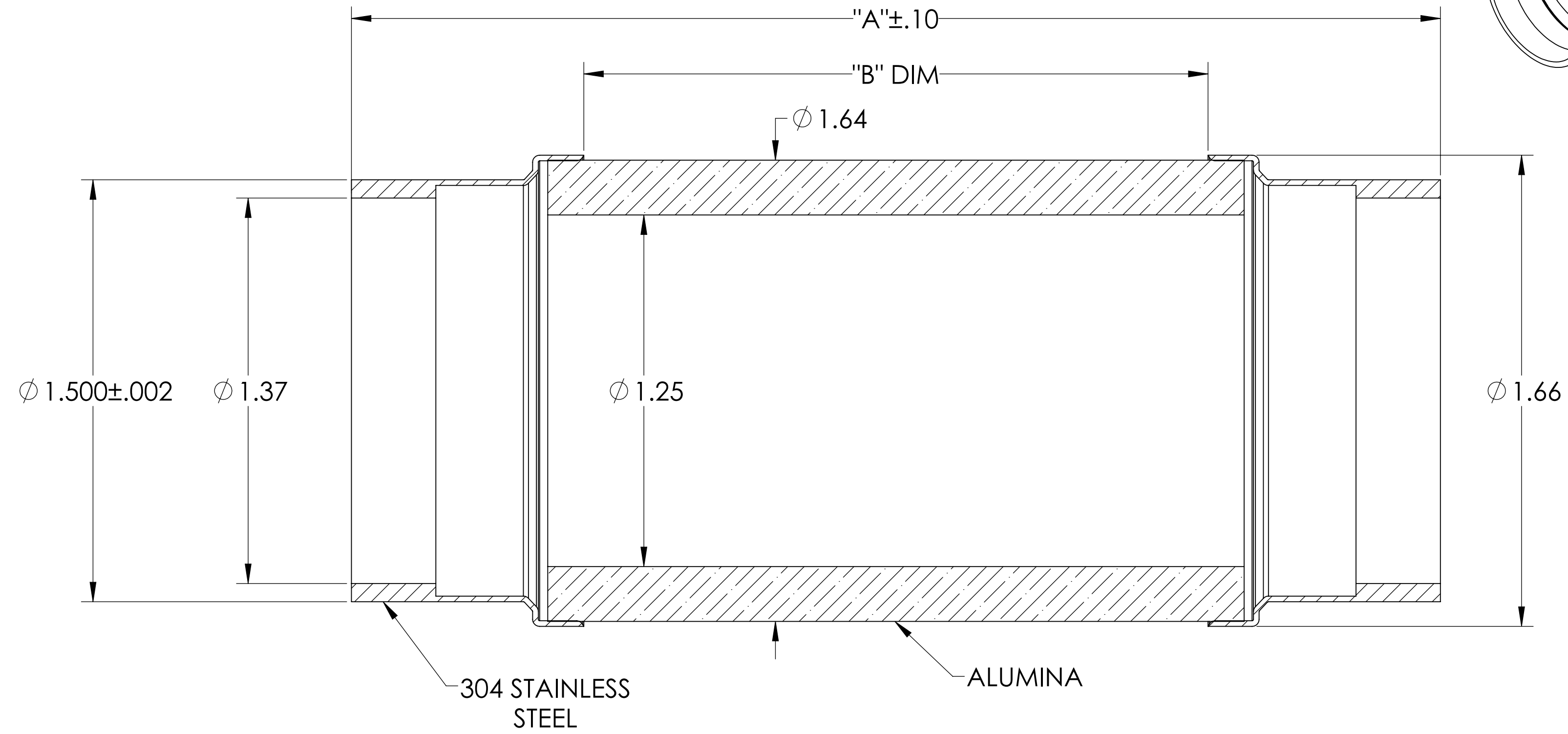
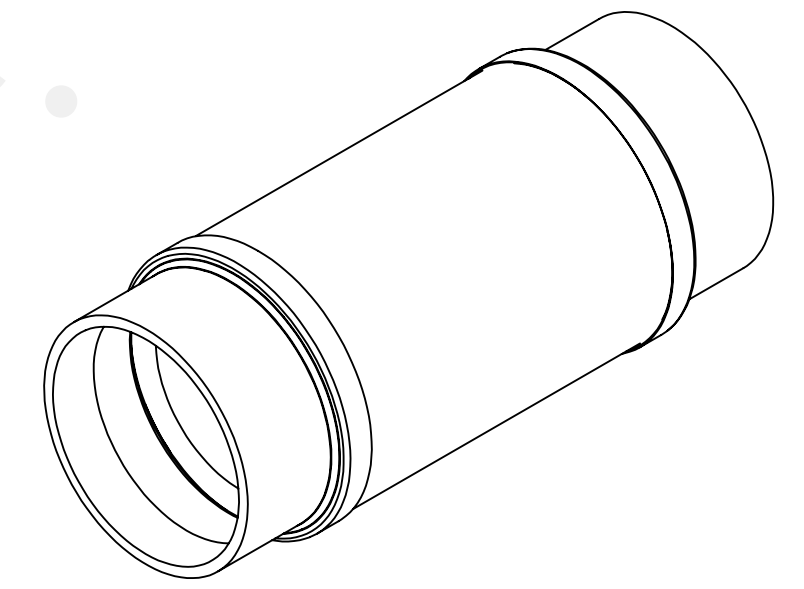

PART #	"A"±.10	("B") MIN	KV RATING
A0594-1-W	2.20	.32	5
A0594-2-W	3.80	2.00	30
A0594-3-W	5.90	4.00	60

SPECIFICATIONS:

1. VOLTAGE: 5, 30, 60KV
2. TEMPERATURE: -200°C TO 450°C
3. LEAK RATE < 1X10-9 ATM CC/SEC HE

Break, 5KV Isolation, 1.25" Inner Dia., 1.50" Dia Stainless Steel Tube Adapters, High Voltage Isolation, Thermal Isolation, Weldable Tube Ends, UHV Compatible

UNLESS OTHERWISE SPECIFIED:		QUOTATION #		N/A		
DIMENSIONS ARE IN INCHES		NAME	DATE	MPF PRODUCTS INC. TITLE: BREAK, 5, 30, 60KV ISOLATION, 1.25" INNER DIA, 1.50" DIA STAINLESS STEEL TUBE ADAPTERS DOWNLOADED FROM MPFPI.COM		
TOLERANCES:		DRAWN	WJ			9/11/2015
ANGULAR: MACH± 1/2"		CHECKED				9/11/2015
TWO PLACE DECIMAL ± .030		ENG APPR.	WJ			9/11/2015
THREE PLACE DECIMAL ± .015		THIRD ANGLE:				
MATERIAL		APPLICATION		DWG. NO.		
		NEXT ASSY	USED ON	A0594		
FINISH		SURFACE FINISH:		REV		
		63/ OR BETTER		Wednesday, October 16, 2019 10:51:37 AM		
PLATING		UNLESS OTHERWISE SPECIFIED:				
		ALL DIAMETERS CONCENTRIC WITHIN .005. REMOVE ALL BURRS AND SHARP EDGES				