

MPF PRODUCTS INC.

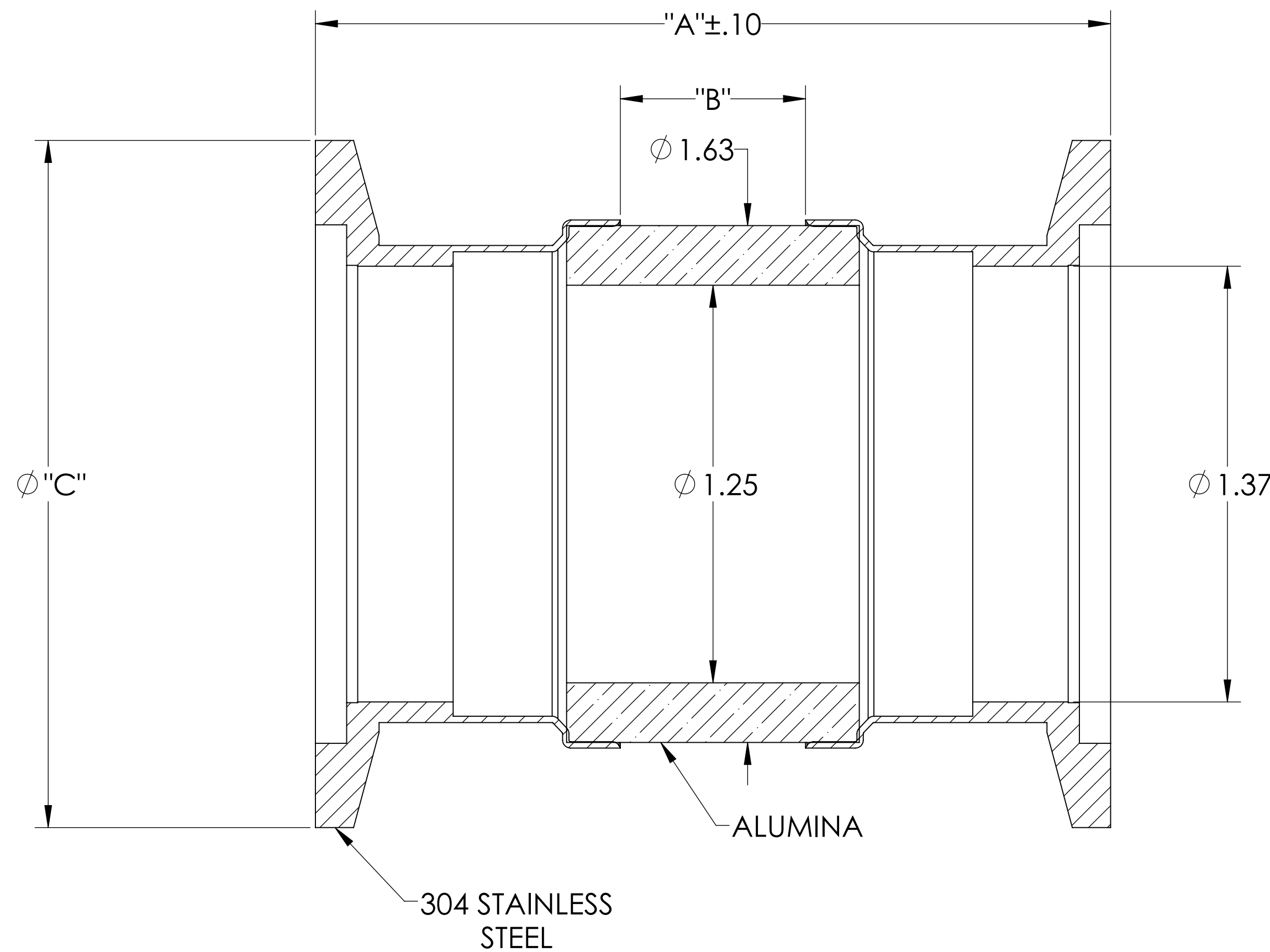
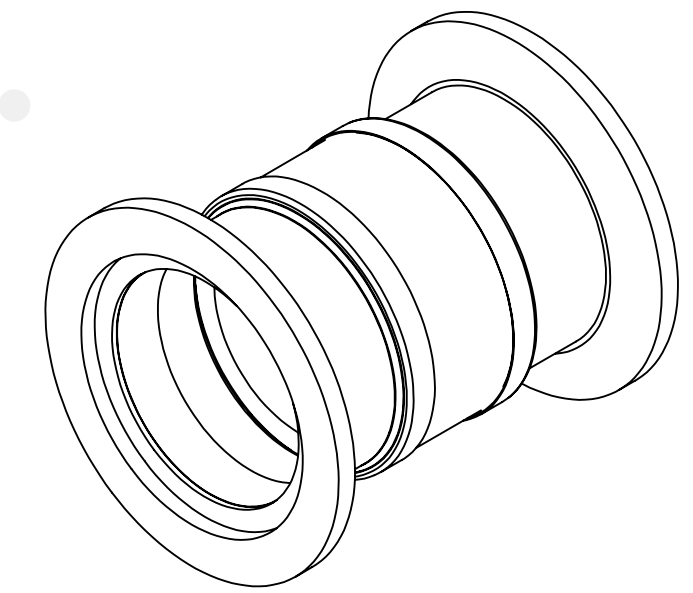

PART #	"A" ± .10	("B") MIN	Ø"C"	KV RATING
A0597-1-QF	2.50	.250	2.16	5
A0579-2-QF	4.03	2.00	2.16	30
A0597-3-QF	2.50	.250	2.95	5
A0597-4-QF	4.03	2.00	2.95	30
A0597-5-QF	6.17	4.00	2.16	60
A0597-6-QF	6.17	4.00	2.95	60

SPECIFICATIONS:

1. VOLTAGE: 5, 30, 60KV
2. TEMPERATURE: -200°C TO 450°C
3. LEAK RATE < 1X10⁻⁹ ATM CC/SEC HE

Break, 5, 30, 60KV Isolation, 1.25" Inner Dia, QF/KF, High Voltage Isolation, Thermal Isolation, UHV Compatible

UNLESS OTHERWISE SPECIFIED:		QUOTATION #		N/A	
DIMENSIONS ARE IN INCHES TOLERANCES:		NAME	DATE	MPF PRODUCTS INC. TITLE: BREAK, 5, 30, 60KV ISOLATION, 1.25" INNER DIA, QF/KF DOWNLOADED FROM MPFPI.COM DWG. NO. A0597 REV	
ANGULAR: MACH ± 1/2°		DRAWN	9/11/2015		
TWO PLACE DECIMAL ± .030		CHECKED	9/11/2015		
THREE PLACE DECIMAL ± .015		ENG APPR.	9/11/2015		
MATERIAL		THIRD ANGLE:			
FINISH		APPLICATION			
PLATING		NEXT ASSY		USED ON	
SURFACE FINISH: 63/ OR BETTER		UNLESS OTHERWISE SPECIFIED:		Friday, January 25, 2019 11:57:09 AM	
ALL DIAMETERS CONCENTRIC WITHIN .005. REMOVE ALL BURRS AND SHARP EDGES					