

MPF PRODUCTS INC.

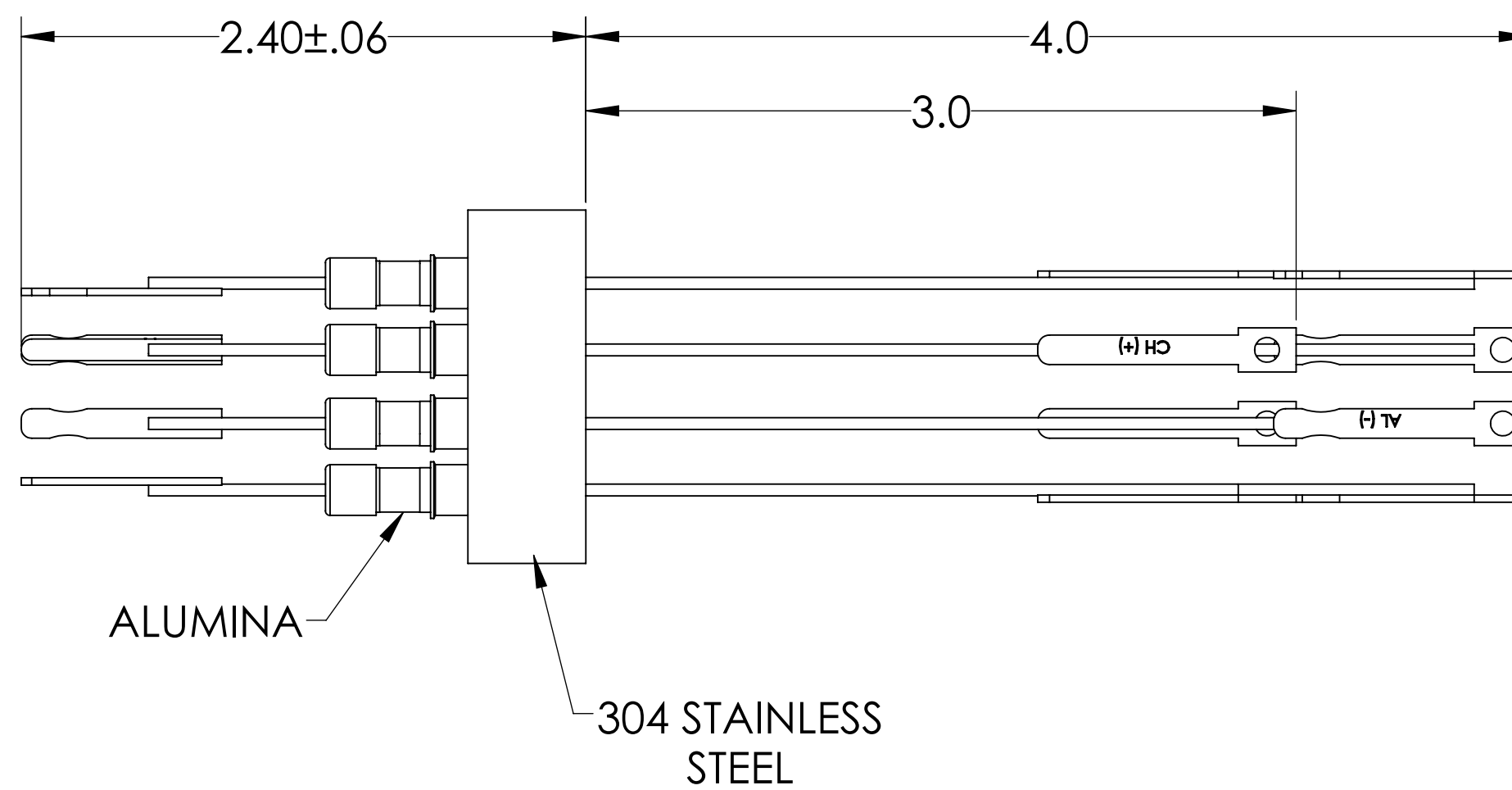

PART #	T/C TYPE
A0720-1-W	K
A0720-2-W	J
A0720-3-W	E
A0720-4-W	C

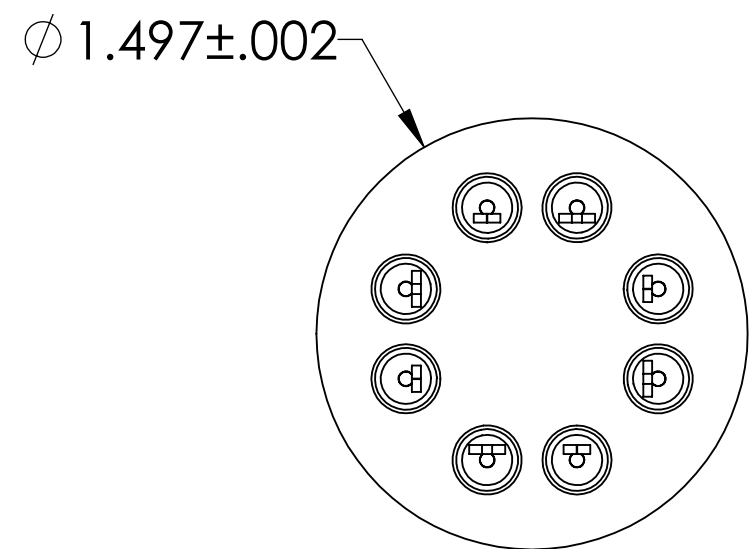
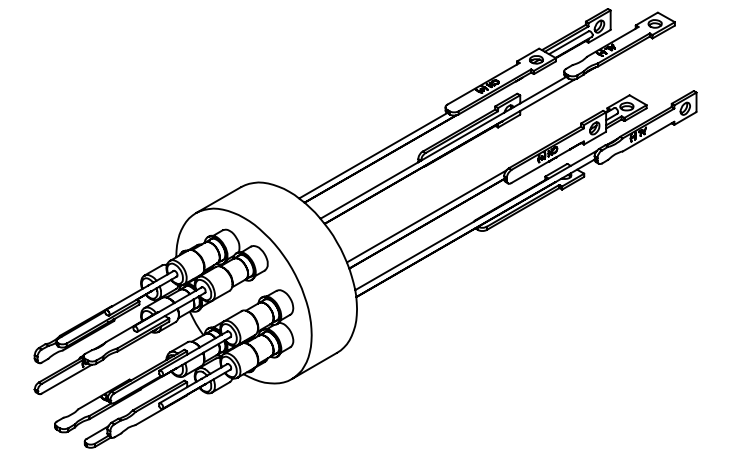
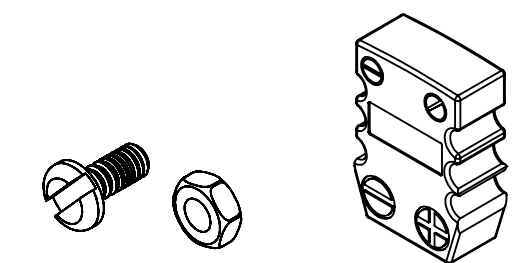

SPECIFICATIONS:

1. TEMPERATURE RATING: -100 TO 450°C
2. LEAK RATE <math>< 1 \times 10^{-9}</math> ATM CC/SEC HE

Thermocouple Feedthrough, 4 Pairs, Miniature Connector, 1.50" Stainless Steel Weld Adapter

UNLESS OTHERWISE SPECIFIED:	QUOTATION #	N/A	
DIMENSIONS ARE IN INCHES TOLERANCES:	DRAWN	NAME	DATE
ANGULAR: MACH $\pm 1/2^\circ$	WJ	WJ	9/11/2015
TWO PLACE DECIMAL $\pm .030$	CHECKED		9/11/2015
THREE PLACE DECIMAL $\pm .015$	ENG APPR.	WJ	9/11/2015
MATERIAL	THIRD ANGLE:		
FINISH	APPLICATION		
PLATING	NEXT ASSY	USED ON	
	SURFACE FINISH:	$\sqrt{63}$ OR BETTER	
	UNLESS OTHERWISE SPECIFIED:	ALL DIAMETERS CONCENTRIC WITHIN .005. REMOVE ALL BURRS AND SHARP EDGES	
	FRIDAY, FEBRUARY 8, 2019 8:32:56 AM		

MPF PRODUCTS INC.
 TITLE:
**THERMOCOUPLE, 4 PAIRS,
 CONNECTOR, 1.497"
 WELD ADAPTER**

DOWNLOADED FROM MPFPI.COM
 DWG. NO. **A0720** REV