

MPF PRODUCTS INC.

Ø 2.95
QF 50

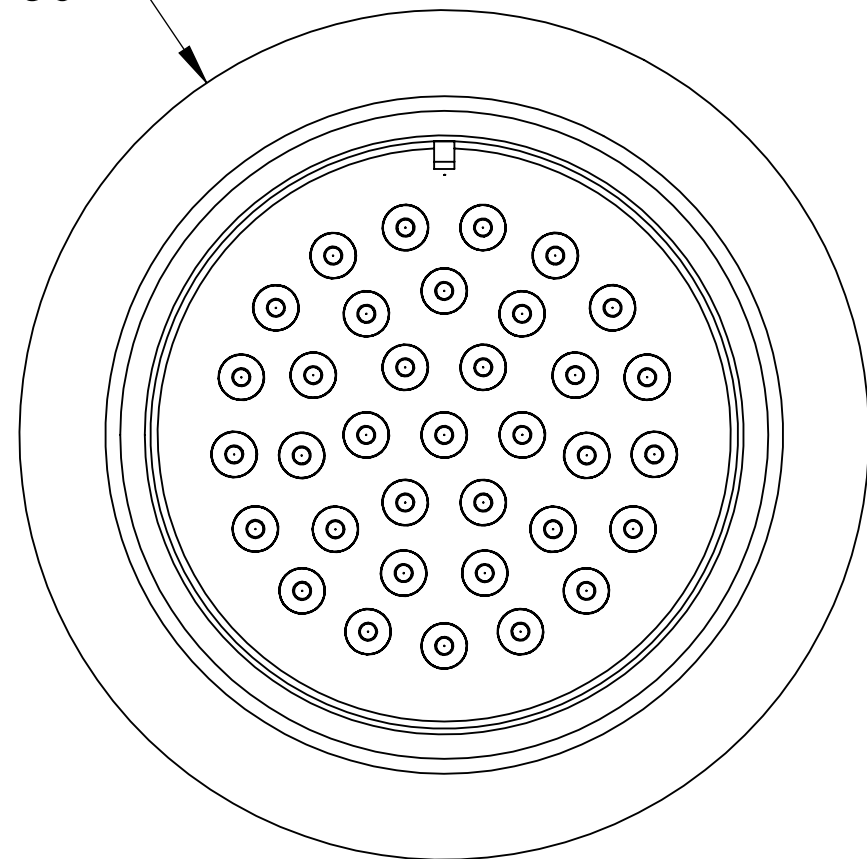

2-1/4"-16 THREAD

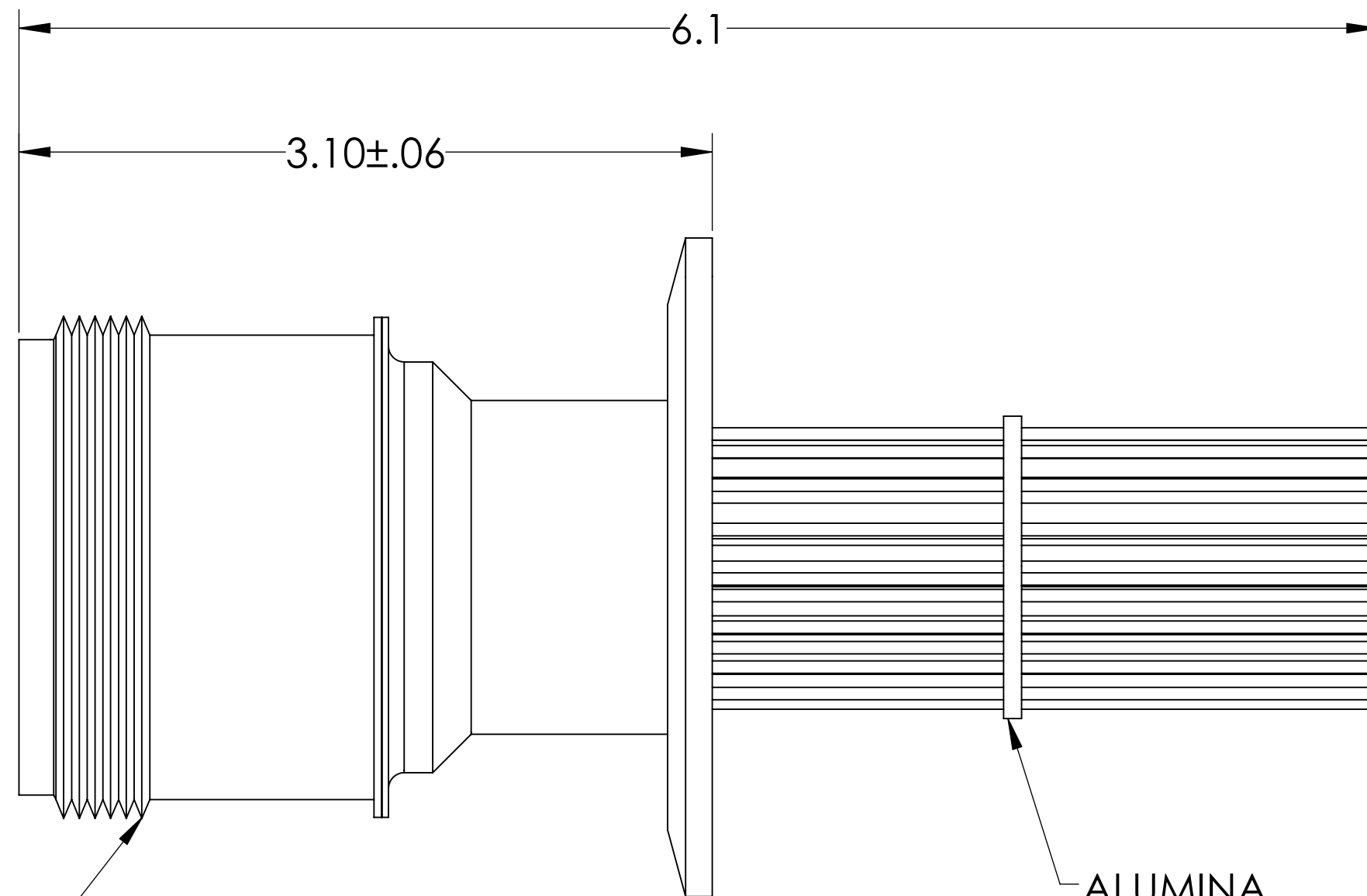

304 STAINLESS
STEEL FLANGE

ALUMINA
SPACER

Ø .056±.002
ALUMEL

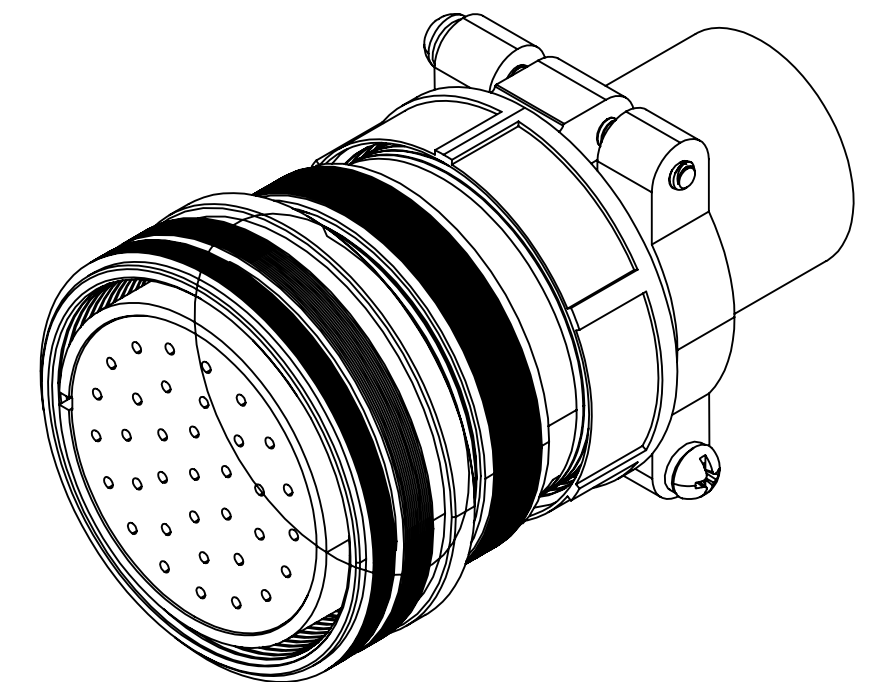
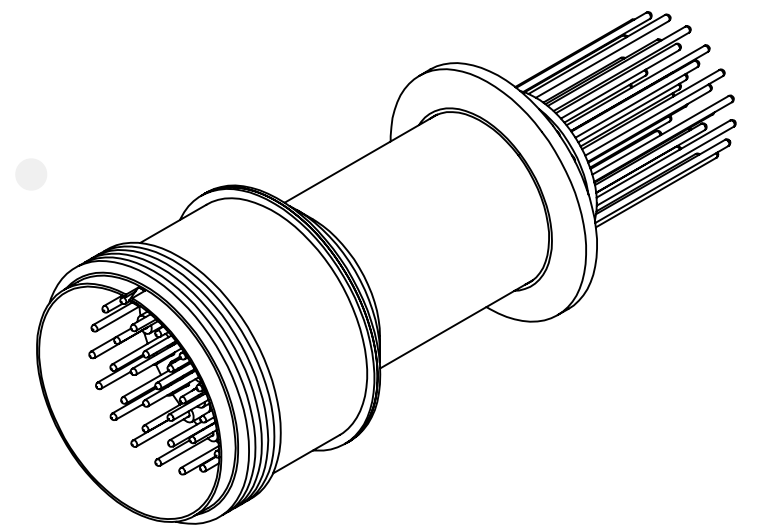

SPECIFICATIONS:

1. VOLTAGE: 700 VOLTS DC
2. CURRENT: 10 AMPS PER PIN, 100 AMPS FULL LOAD
3. TEMPERATURE RATING: -100 TO 450°C WITHOUT CONNECTOR
4. LEAK RATE < 1X10-9 ATM CC/SEC HE

MS Series, Multipin Feedthrough, 35 Pins, 700 Volts, 10 Amps per Pin, 0.056" Dia Conductors w/ Air-side Connector, QF/KF

UNLESS OTHERWISE SPECIFIED:		QUOTATION #		N/A	
DIMENSIONS ARE IN INCHES TOLERANCES:		NAME	DATE	MPF PRODUCTS INC.	
ANGULAR: MACH ± 1/2°		DRAWN	9/11/2015		
TWO PLACE DECIMAL ± .030		CHECKED	9/11/2015		
THREE PLACE DECIMAL ± .015		ENG APPR.	WJ 9/11/2015		
MATERIAL		THIRD ANGLE:		TITLE: MULTIPIN, 35 PINS, 700V, 10A, QF/KF	
FINISH					
PLATING		APPLICATION NEXT ASSY USED ON			
SURFACE FINISH: 63 OR BETTER		SURFACE FINISH: 63 OR BETTER		DOWNLOADED FROM MPFPI.COM DWG. NO. REV	
UNLESS OTHERWISE SPECIFIED:		UNLESS OTHERWISE SPECIFIED: ALL DIAMETERS CONCENTRIC WITHIN .005. REMOVE ALL BURRS AND SHARP EDGES		A0745-2-QF REV	
		Monday, April 22, 2024 8:32:55 AM			