

MPF PRODUCTS INC.

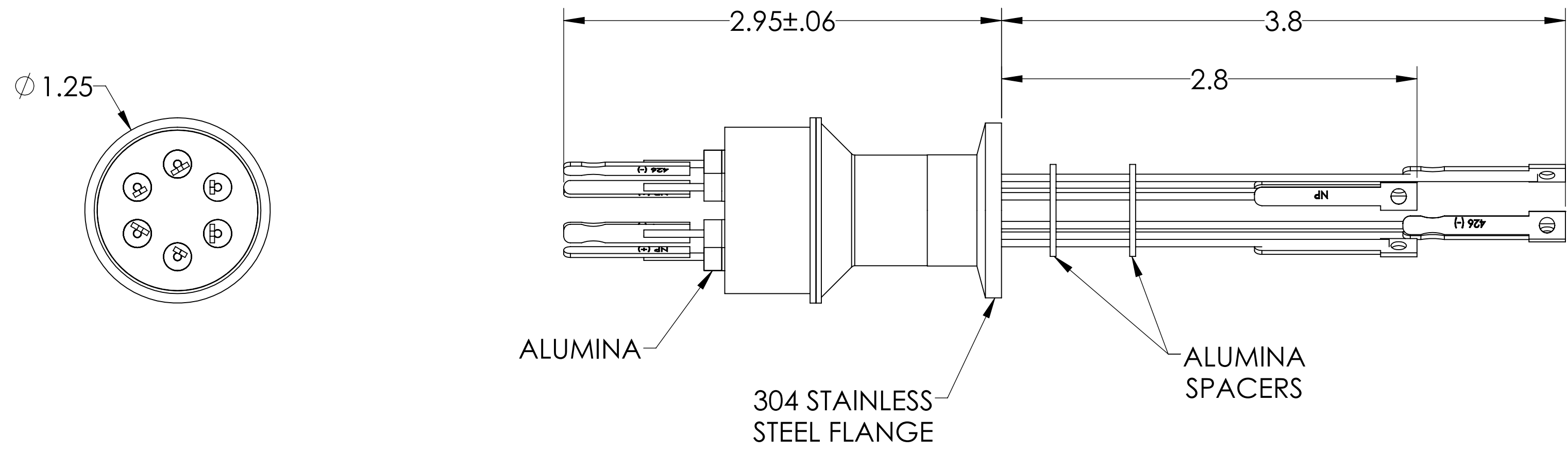

PART #	T/C TYPE
A0782-1-QF	K
A0782-2-QF	J
A0782-3-QF	E
A0782-4-QF	C

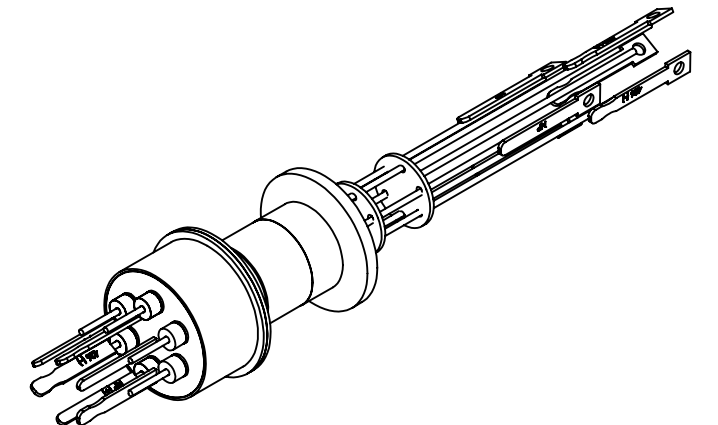
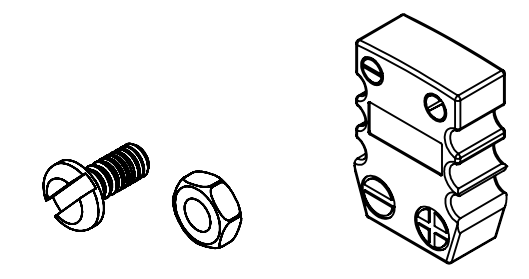

SPECIFICATIONS:
 1. TEMPERATURE RATING: -100 TO 450°C
 2. LEAK RATE < 1X10-9 ATM CC/SEC HE

Thermocouple Feedthrough, 3 Pairs, Miniature Connector, 1.18" QF/KF

UNLESS OTHERWISE SPECIFIED:		QUOTATION #		N/A	
DIMENSIONS ARE IN INCHES TOLERANCES:		NAME	DATE	MPF PRODUCTS INC.	
ANGULAR: MACH ± 1/2°		DRAWN	9/11/2015		
TWO PLACE DECIMAL ± .030		CHECKED	9/11/2015		
THREE PLACE DECIMAL ± .015		ENG APPR.	9/11/2015		
MATERIAL		THIRD ANGLE:		THERMOCOUPLE, 3 PAIRS, CONNECTOR, 1.18" QF/KF	
FINISH		APPLICATION			
PLATING		NEXT ASSY USED ON			
SURFACE FINISH: 63/ OR BETTER		UNLESS OTHERWISE SPECIFIED:		DOWNLOADED FROM MPFPI.COM	
ALL DIAMETERS CONCENTRIC WITHIN .005. REMOVE ALL BURRS AND SHARP EDGES		DWG. NO.		REV	
		A0782		Friday, February 8, 2019 8:31:22 AM	