

MPF PRODUCTS INC.

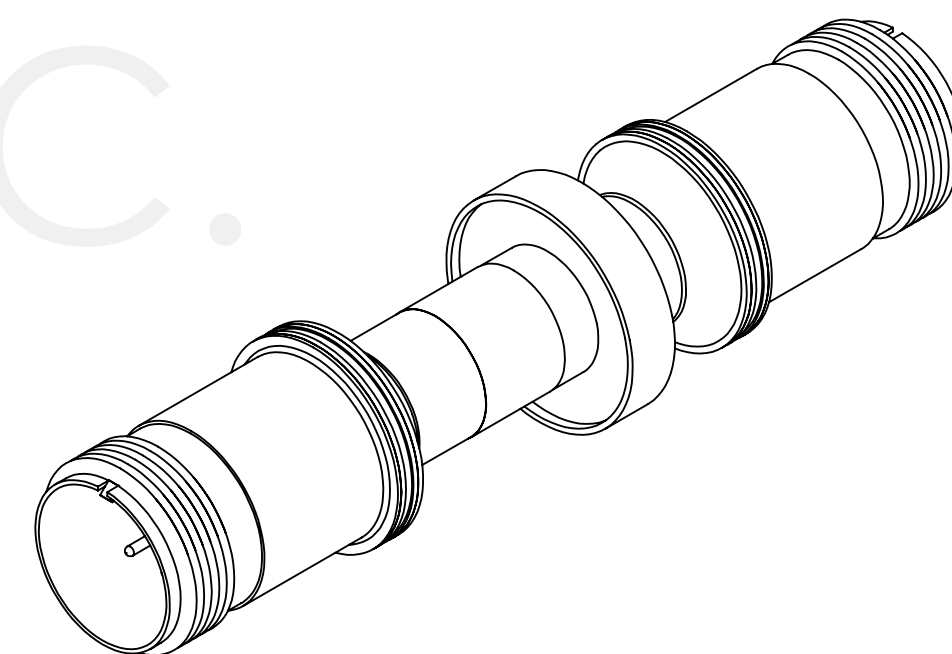

VACUUM SIDE

AIRSIDE

$\phi 1.372 \pm .002$

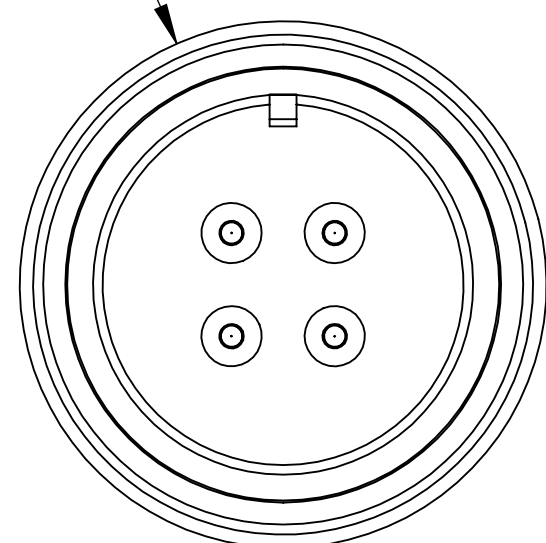

2X 1-1/8"-18 THREAD

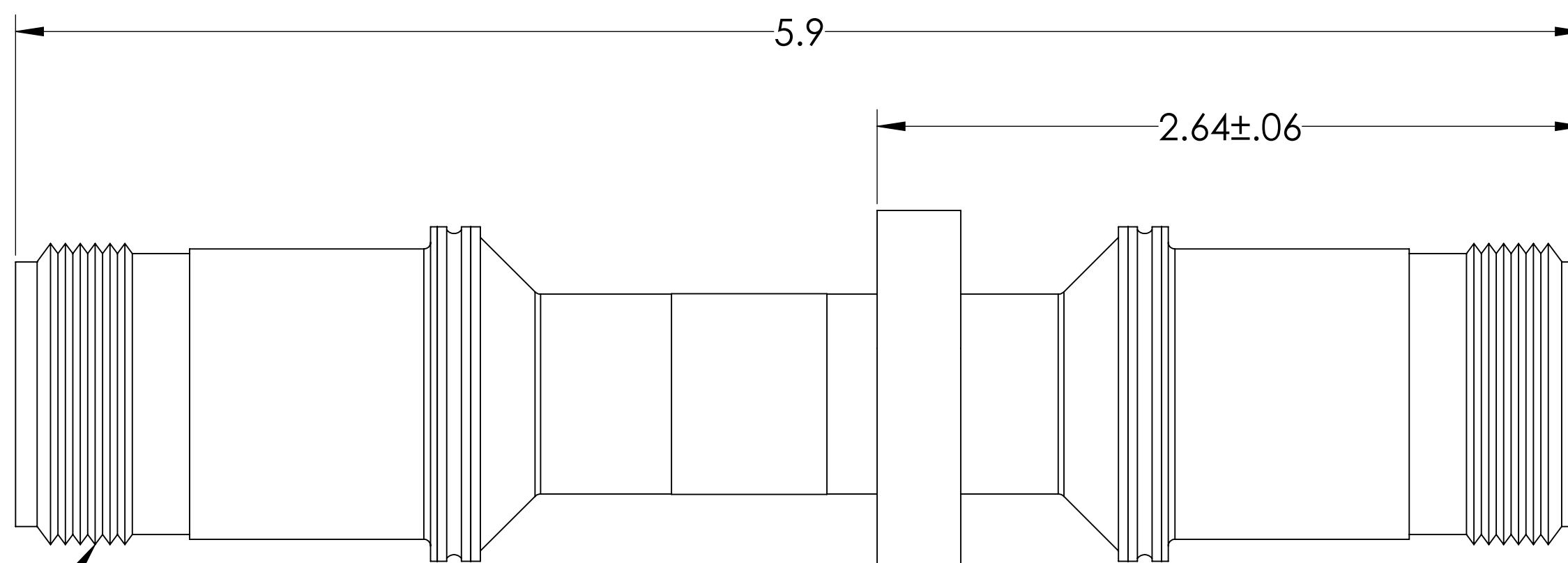

304 STAINLESS STEEL

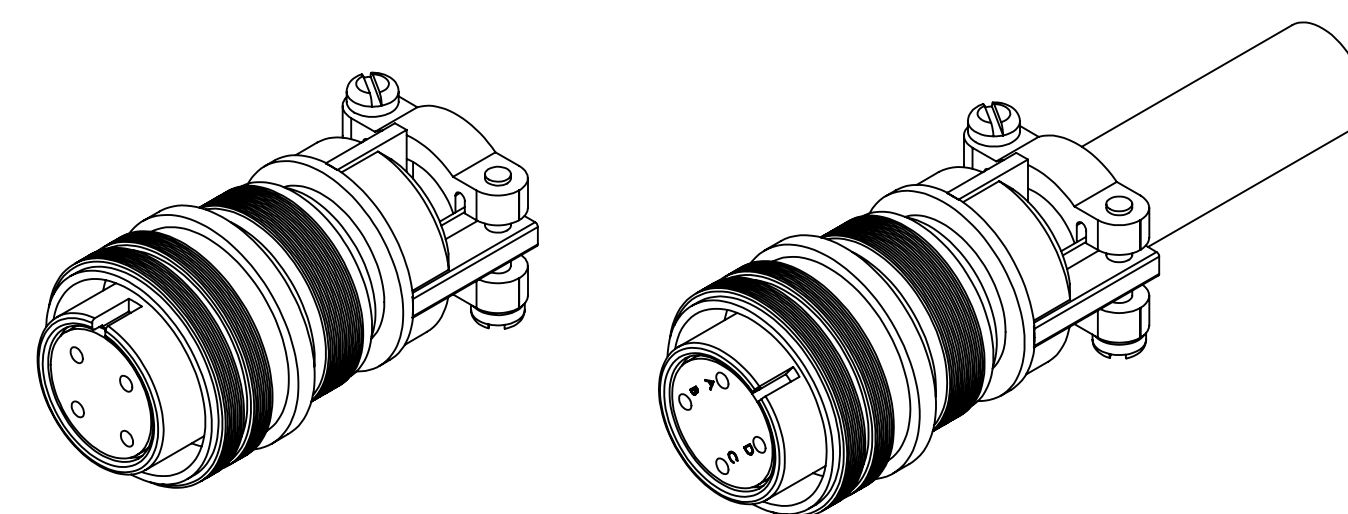

SPECIFICATIONS:

1. VOLTAGE: 700 VOLTS DC
2. CURRENT: 10 AMPS PER PIN, 28 AMPS FULL LOAD
3. TEMPERATURE RATING: -100 TO 450°C WITHOUT CONNECTOR
4. VACUUM SIDE CONNECTOR RATED FOR -100 TO 350 °C
5. LEAK RATE < 1X10-9 ATM CC/SEC HE

MS Series, Multipin Feedthrough, 4 Pins, 700 Volts, 10 Amps per Pin, Double-Ended w/ Air & Vacuum-side Connectors, 1.372" Weld Adapter

UNLESS OTHERWISE SPECIFIED:		QUOTATION #		N/A	
DIMENSIONS ARE IN INCHES		NAME	DATE	MPF PRODUCTS INC.	
TOLERANCES:		DRAWN	9/11/2015		
ANGULAR: MACH ± 1/2°		CHECKED	9/11/2015		
TWO PLACE DECIMAL ± .030		ENG APPR.	9/11/2015		
THREE PLACE DECIMAL ± .015		THIRD ANGLE:		MULTIPIN, 4 PINS, 700V, 10 A, DOUBLE ENDED, 1.372" WELD ADAPTER	
MATERIAL					
FINISH					
PLATING		SURFACE FINISH: 63/ OR BETTER		DOWNLOADED FROM MPFPI.COM	
		UNLESS OTHERWISE SPECIFIED:		DWG. NO. A1086-1-W	
		ALL DIAMETERS CONCENTRIC WITHIN .005. REMOVE ALL BURRS AND SHARP EDGES		REV.	
		Thursday, February 7, 2019 8:35:17 AM			