

# MPF PRODUCTS INC.

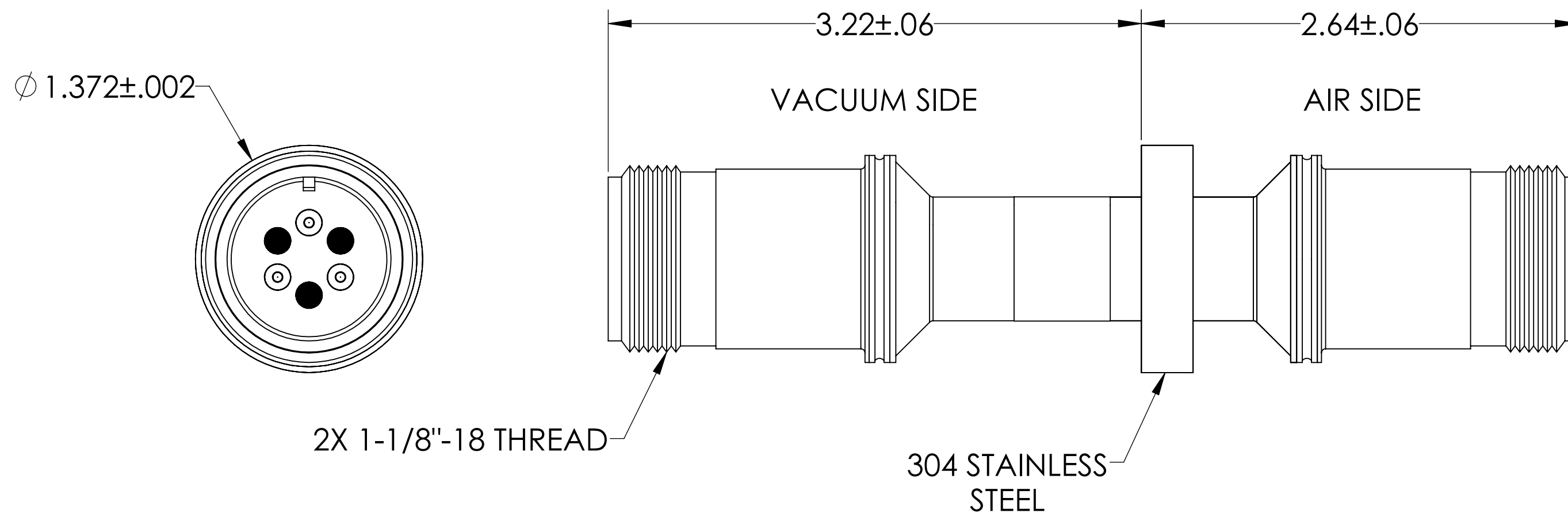
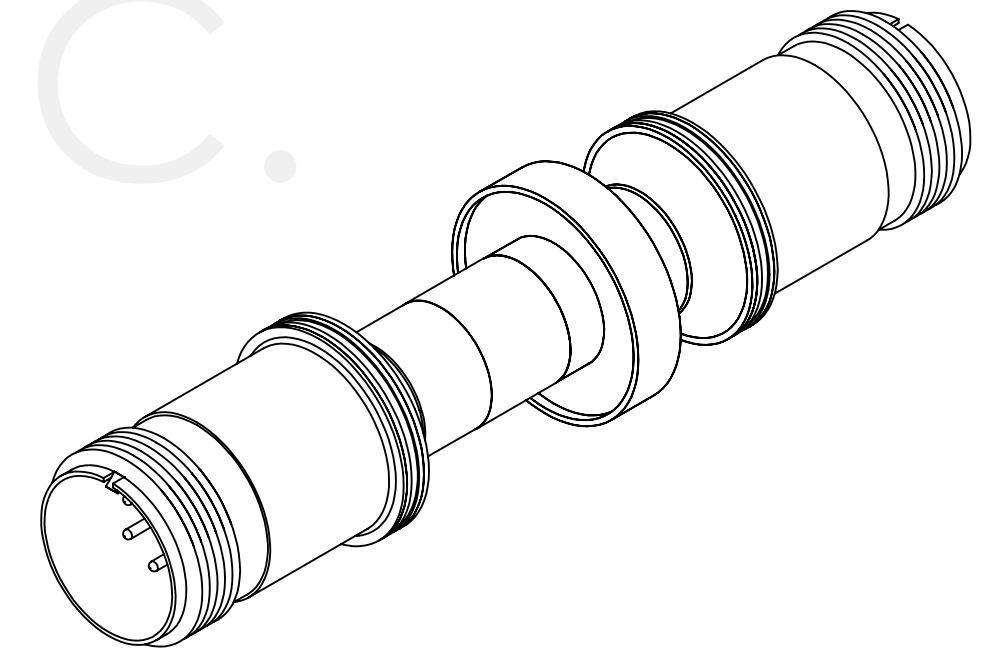

CHROMEL (+)  
NON-MAGNETIC

CONSTANTAN (-)  
NON-MAGNETIC

AIR-SIDE  
CONNECTOR

VACUUM-SIDE  
CONNECTOR

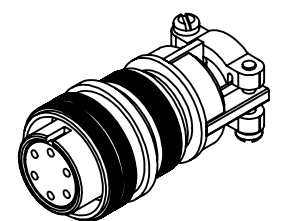
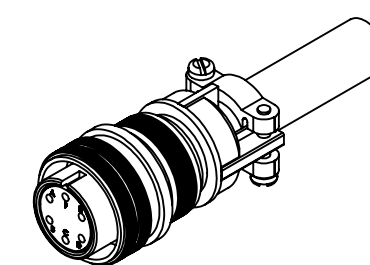

**SPECIFICATIONS:**

1. TEMPERATURE RATING: -100 TO 450°C
2. LEAK RATE < 1X10-9 ATM CC/SEC HE

MS Series, Thermocouple Feedthrough, Type E, 3 Pairs, Double-Ended, w/ Air & Vacuum-side Connectors, 1.37" Dia Stainless Steel Weld Adapter

UNLESS OTHERWISE SPECIFIED:		QUOTATION #		N/A	
DIMENSIONS ARE IN INCHES TOLERANCES:		NAME	DATE	<b>MPF PRODUCTS INC.</b>	
ANGULAR: MACH ± 1/2°		DRAWN	9/11/2015		
TWO PLACE DECIMAL ± .030		CHECKED	9/11/2015		
THREE PLACE DECIMAL ± .015		ENG APPR.	9/11/2015		
MATERIAL		THIRD ANGLE:		TITLE: THERMOCOUPLE, TYPE E, 3 PAIRS, MS CONNECTOR, DOUBLE ENDED, 1.372" WELD ADAPTER	
FINISH					
PLATING		APPLICATION: NEXT ASSY      USED ON			
SURFACE FINISH:		63/ OR BETTER		DOWNLOADED FROM MPFPI.COM	
UNLESS OTHERWISE SPECIFIED:		ALL DIAMETERS CONCENTRIC WITHIN .005. REMOVE ALL BURRS AND SHARP EDGES		DWG. NO.	REV
				A1093-1-W	
				Friday, February 8, 2019 10:47:43 AM	