

MPF PRODUCTS INC.

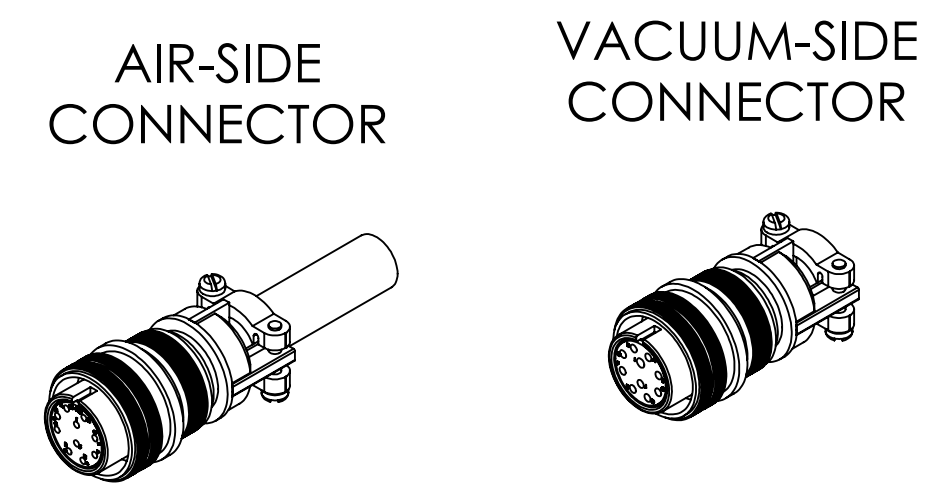
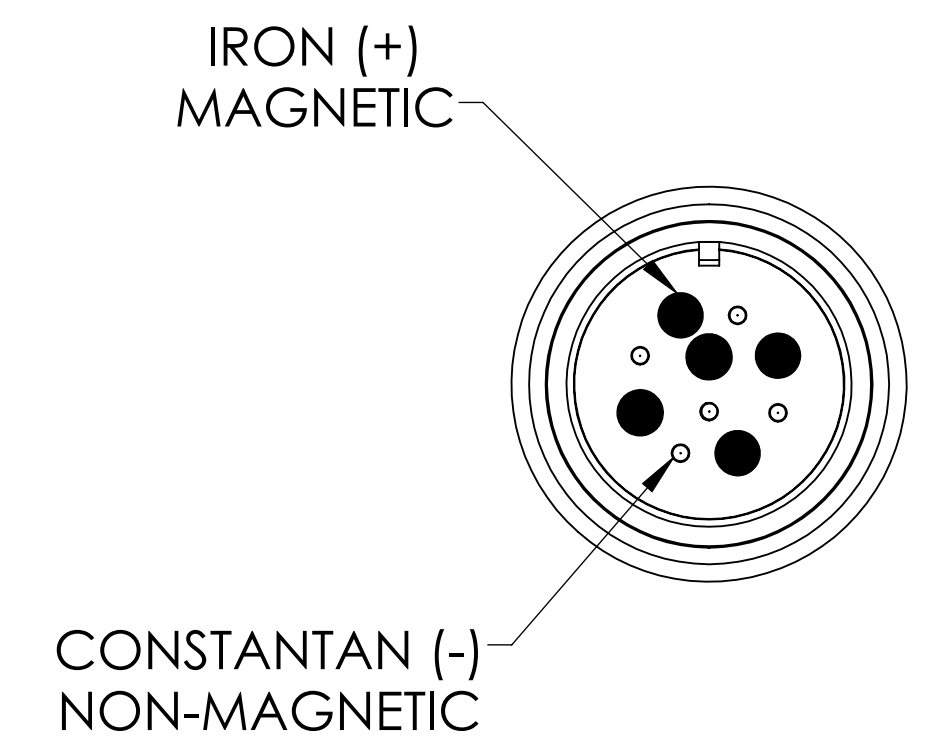
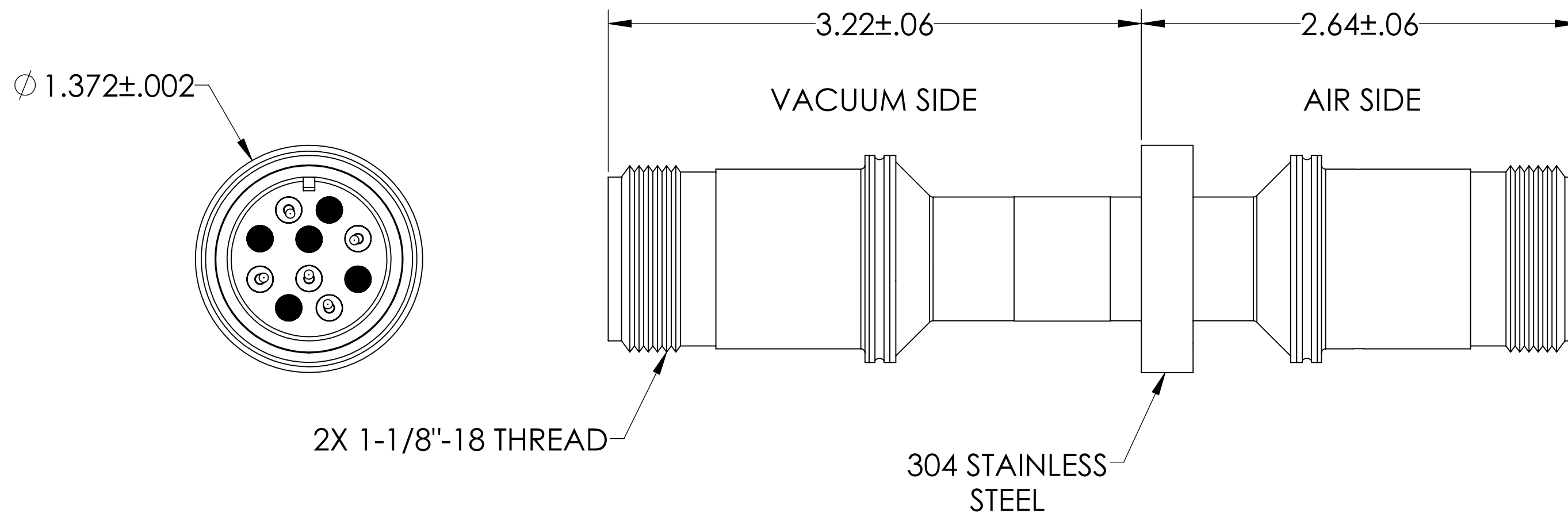
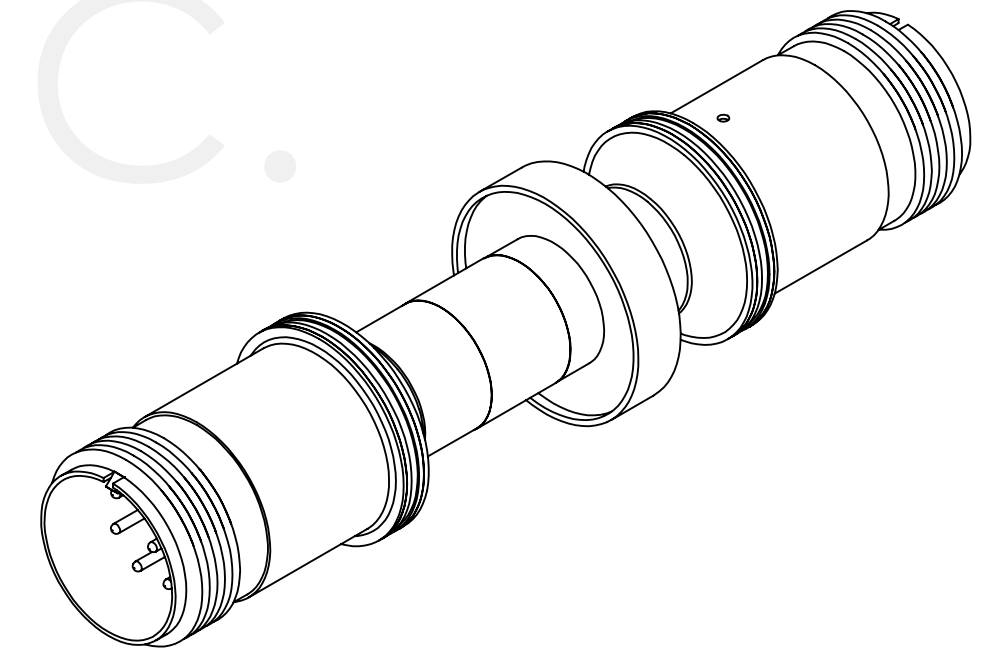

- SPECIFICATIONS:**
1. TEMPERATURE RATING: -100 TO 450°C
 2. LEAK RATE < 1X10-9 ATM CC/SEC HE

MS Series, Thermocouple Feedthrough, Type J, 5 Pairs, Double-Ended, w/ Air & Vacuum-side Connectors, 1.37" Dia Stainless Steel Weld Adapter

UNLESS OTHERWISE SPECIFIED:	QUOTATION #	N/A	
DIMENSIONS ARE IN INCHES TOLERANCES:	NAME	DATE	MPF PRODUCTS INC.
ANGULAR: MACH ± 1/2°	DRAWN	9/11/2015	
TWO PLACE DECIMAL ± .030	CHECKED	9/11/2015	
THREE PLACE DECIMAL ± .015	ENG APPR.	WJ 9/11/2015	
MATERIAL	THIRD ANGLE:	TITLE: THERMOCOUPLE, TYPE J, 5 PAIRS, MS CONNECTOR, DOUBLE ENDED, 1.372" WELD ADAPTER	
	APPLICATION	DOWNLOADED FROM MPFPI.COM	
	NEXT ASSY	USED ON	DWG. NO.
FINISH	SURFACE FINISH:	63 OR BETTER	REV
PLATING	UNLESS OTHERWISE SPECIFIED:	A1096-1-W	
	ALL DIAMETERS CONCENTRIC WITHIN .005. REMOVE ALL BURRS AND SHARP EDGES	Friday, February 8, 2019 10:45:06 AM	