

# MPF PRODUCTS INC.

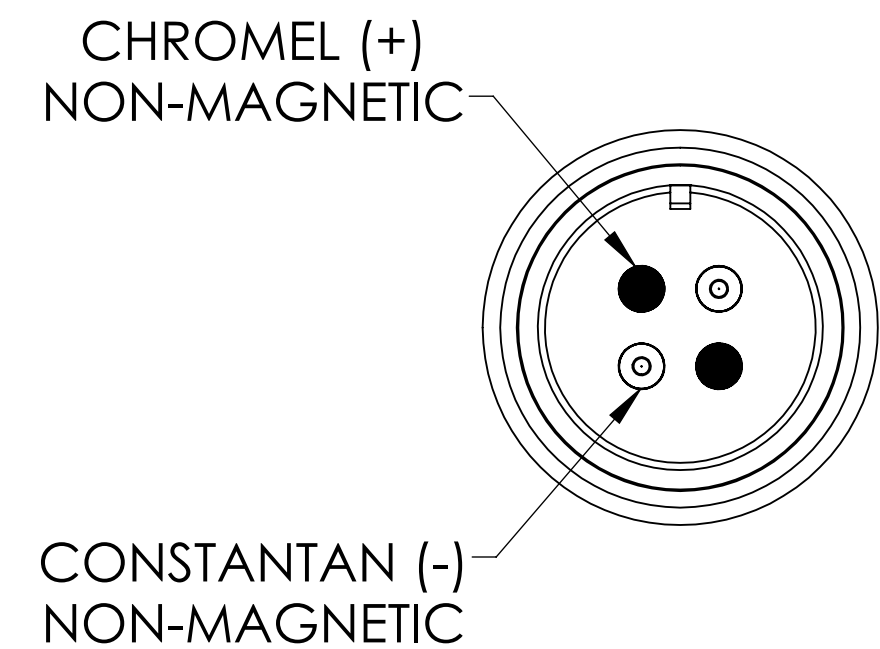

AIR-SIDE CONNECTOR

VACUUM-SIDE CONNECTOR

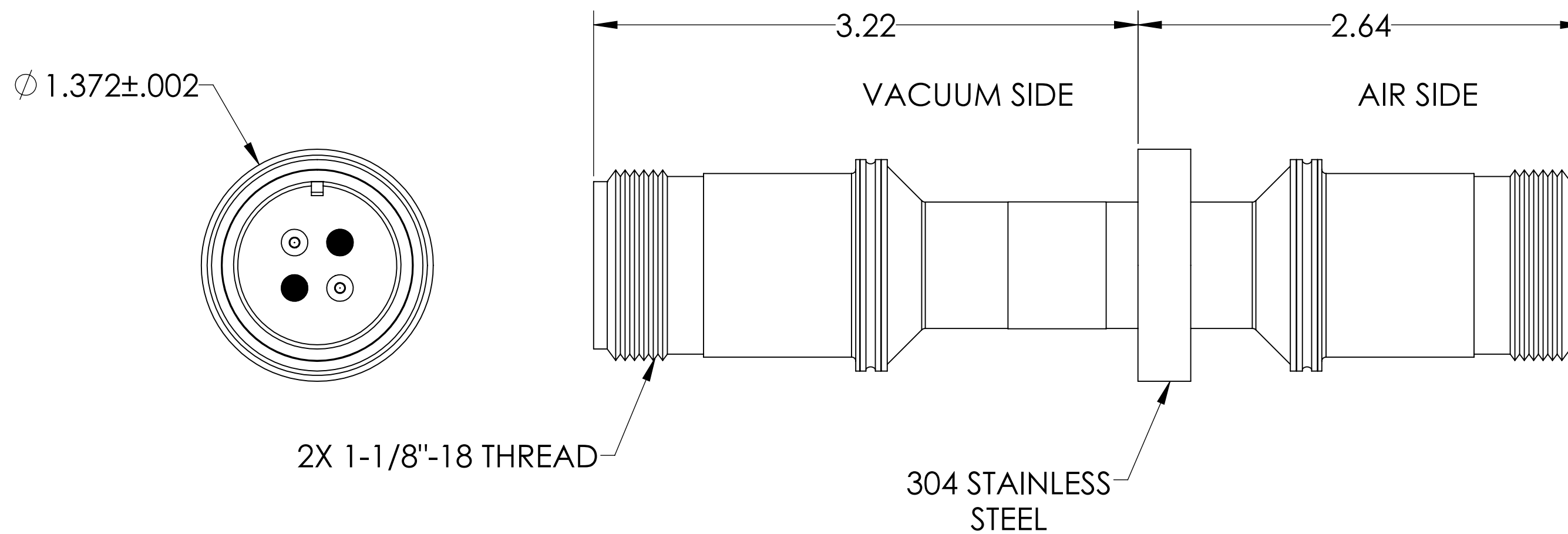
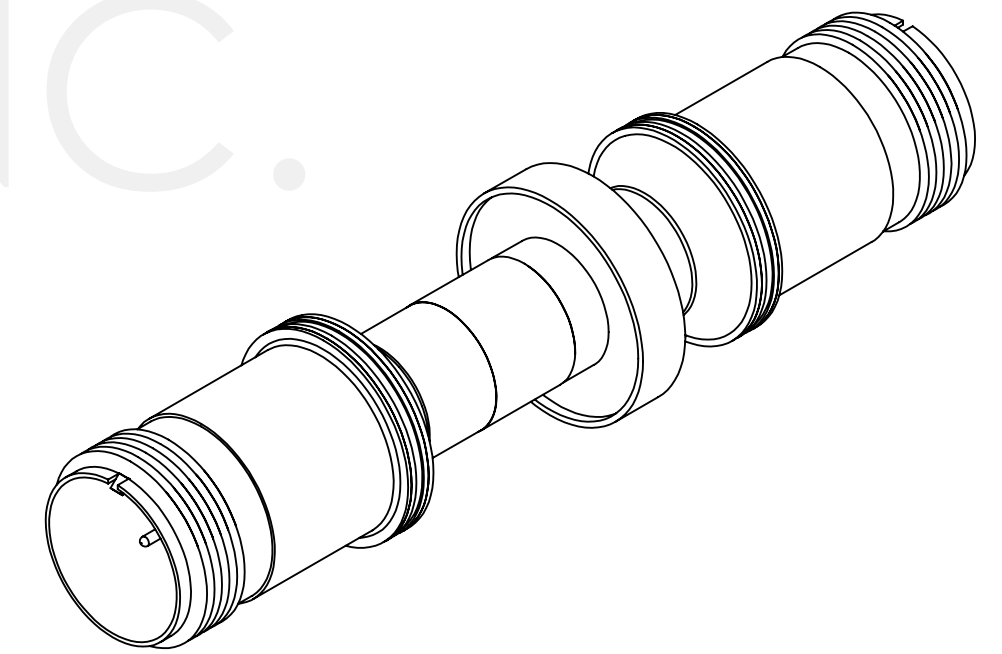
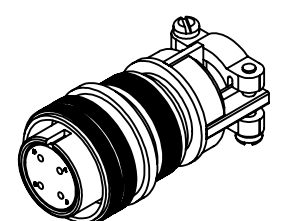
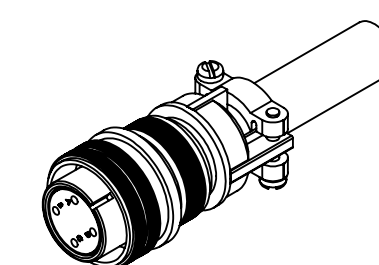

**SPECIFICATIONS:**

1. TEMPERATURE RATING: -100 TO 450°C
2. LEAK RATE < 1X10-9 ATM CC/SEC HE

MS Series, Thermocouple Feedthrough, Type E, 2 Pairs, Double-Ended, w/ Air & Vacuum-side Connectors, 1.37" Dia Stainless Steel Weld Adapter

UNLESS OTHERWISE SPECIFIED:		QUOTATION #		N/A	
DIMENSIONS ARE IN INCHES TOLERANCES:		NAME	DATE	MPF PRODUCTS INC.	
ANGULAR: MACH ± 1/2°		DRAWN	9/11/2015		
TWO PLACE DECIMAL ± .030		CHECKED	9/11/2015		
THREE PLACE DECIMAL ± .015		ENG APPR.	WJ 9/11/2015		
MATERIAL		THIRD ANGLE:		TITLE: THERMOCOUPLE, TYPE E, 2 PAIRS, MS CONNECTOR, DOUBLE ENDED, 1.372" WELD ADAPTER DOWNLOAD FROM MPFPI.COM	
FINISH		APPLICATION			
PLATING		NEXT ASSY	USED ON		
		SURFACE FINISH: 63/ OR BETTER			
		UNLESS OTHERWISE SPECIFIED:		DWG. NO. A1149-1-W	
		ALL DIAMETERS CONCENTRIC WITHIN .005. REMOVE ALL BURRS AND SHARP EDGES		REV	
		Friday, February 8, 2019 10:55:50 AM			