

MPF PRODUCTS INC.

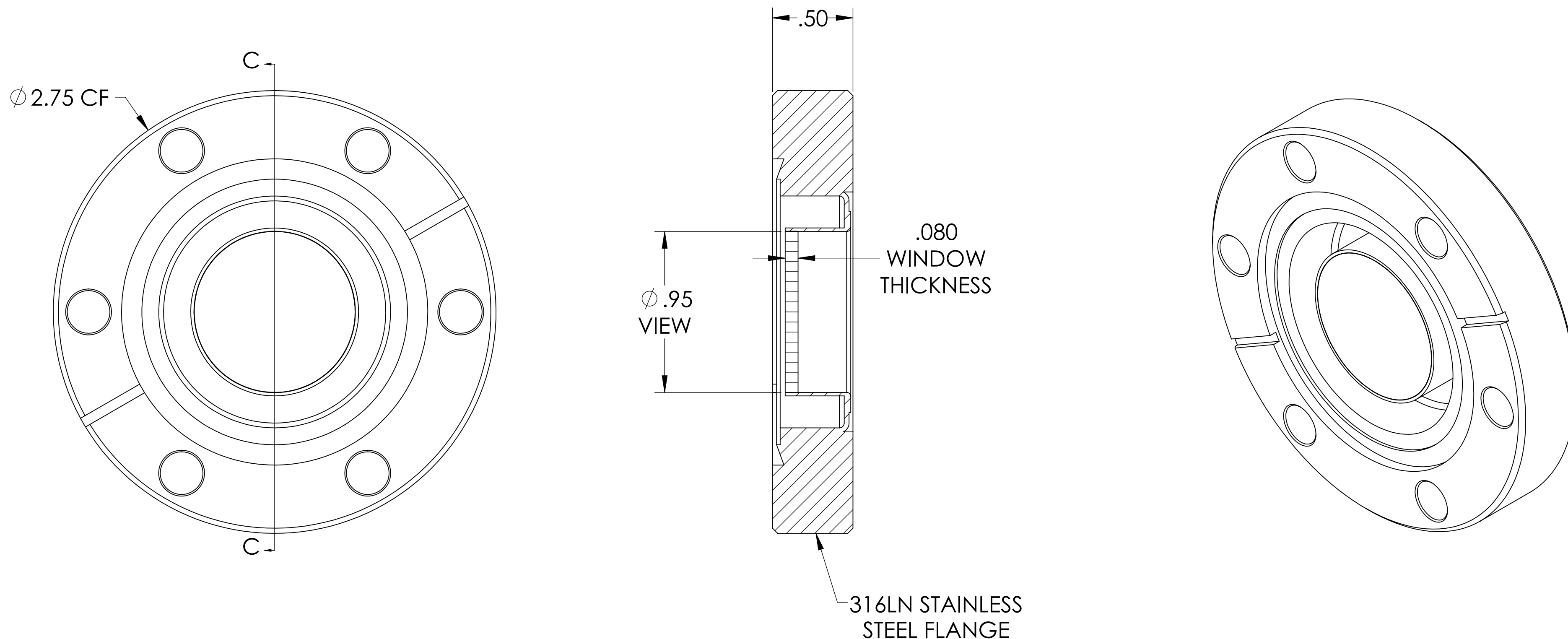

SPECIFICATIONS:

1. MATERIAL: SAPPHIRE
2. TWD < 8λ @ 632nm (PEAK TO VALLEY)
3. PARALLELISM < 3 ARC MINUTES
4. SURFACE FINISH: 50-20 SCRATCH-DIG
5. THERMAL RANGE: -100°C TO 450°C
6. ORIENTATION: RANDOM
7. MAGNETIC PERMEABILITY (μ) < 1.01
8. LEAK RATE < 1×10^{-9} ATM CC/SEC HE

UV Grade Sapphire Viewport, Non-Magnetic, 095" View Dia, 2.75" Conflat Flange

UNLESS OTHERWISE SPECIFIED:	QUOTATION #		N/A
DIMENSIONS ARE IN INCHES TOLERANCES:	DRAWN	NAME	DATE
ANGULAR: MACH $\pm 1/2^\circ$	WJ	WJ	9/11/2015
TWO PLACE DECIMAL $\pm .030$	CHECKED		9/11/2015
THREE PLACE DECIMAL $\pm .015$	ENG APPR.	WJ	9/11/2015
MATERIAL	THIRD ANGLE:		
FINISH	APPLICATION		
PLATING	NEXT ASSY	USED ON	
	SURFACE FINISH: $\sqrt{63}$ OR BETTER		
	UNLESS OTHERWISE SPECIFIED:		
	ALL DIAMETERS CONCENTRIC WITHIN .005. REMOVE ALL BURRS AND SHARP EDGES		
TITLE:		VIEWPORT, SAPPHIRE, UV, NON-MAGNETIC, 1" VIEW, 275CF	
DWG. NO.		A12271-1-CF	
REV		REV	
DOWNLOADED FROM MPFPI.COM		Friday, January 25, 2019 4:25:00 PM	