

MPF PRODUCTS INC.

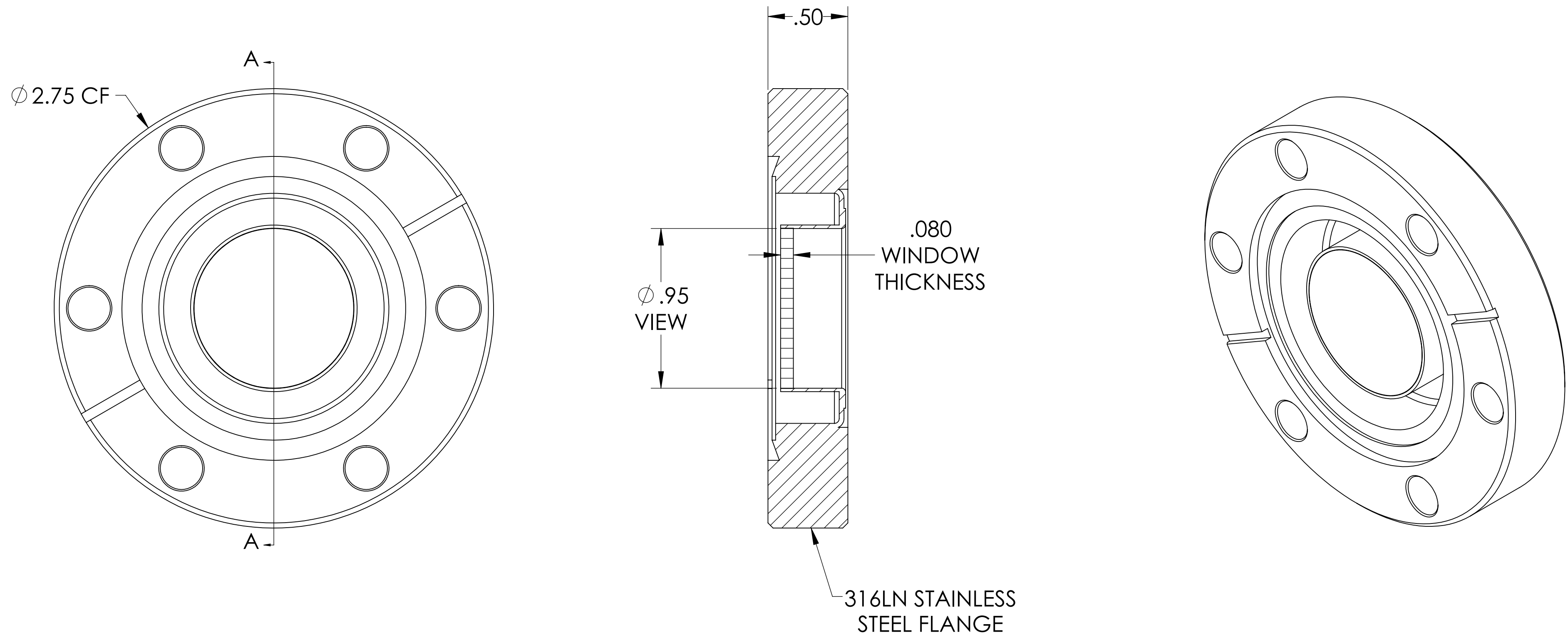

SPECIFICATIONS:

1. MATERIAL: SAPPHIRE
2. TWD <math>< 8\lambda @ 632\text{nm}</math> (PEAK TO VALLEY)
3. PARALLELISM <math>< 3</math> ARC MINUTES
4. SURFACE FINISH: 20-10 SCRATCH-DIG
5. THERMAL RANGE: -100°C TO 450°C
6. ORIENTATION: 0°
7. MAGNETIC PERMEABILITY (μ) <math>< 1.01</math>
8. LEAK RATE <math>< 1 \times 10^{-9}</math> ATM CC/SEC HE

Laser Grade Sapphire Viewport, Non-Magnetic, 095" View Dia, 2.75" Conflat Flange

UNLESS OTHERWISE SPECIFIED:	QUOTATION #	N/A	
DIMENSIONS ARE IN INCHES TOLERANCES:	DRAWN	NAME	DATE
ANGULAR: MACH $\pm 1/2^{\circ}$	WJ	WJ	9/11/2015
TWO PLACE DECIMAL $\pm .030$	CHECKED		9/11/2015
THREE PLACE DECIMAL $\pm .015$	ENG APPR.	WJ	9/11/2015
MATERIAL	THIRD ANGLE:		
FINISH	APPLICATION		
PLATING	NEXT ASSY		
	USED ON		
	SURFACE FINISH: $\sqrt{63}$ OR BETTER		
	UNLESS OTHERWISE SPECIFIED:		
	ALL DIAMETERS CONCENTRIC WITHIN .005. REMOVE ALL BURRS AND SHARP EDGES		
	TITLE:		REV
	VIEWPORT, SAPPHIRE, LASER GRADE, NON- MAGNETIC, 0.95" VIEW, 275CF		
	DWG. NO.		
	A12272-1-CF		
	DOWNLOADED FROM MPFPI.COM		
	Friday, January 25, 2019 4:24:41 PM		