

MPF PRODUCTS INC.

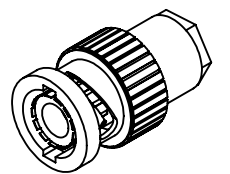
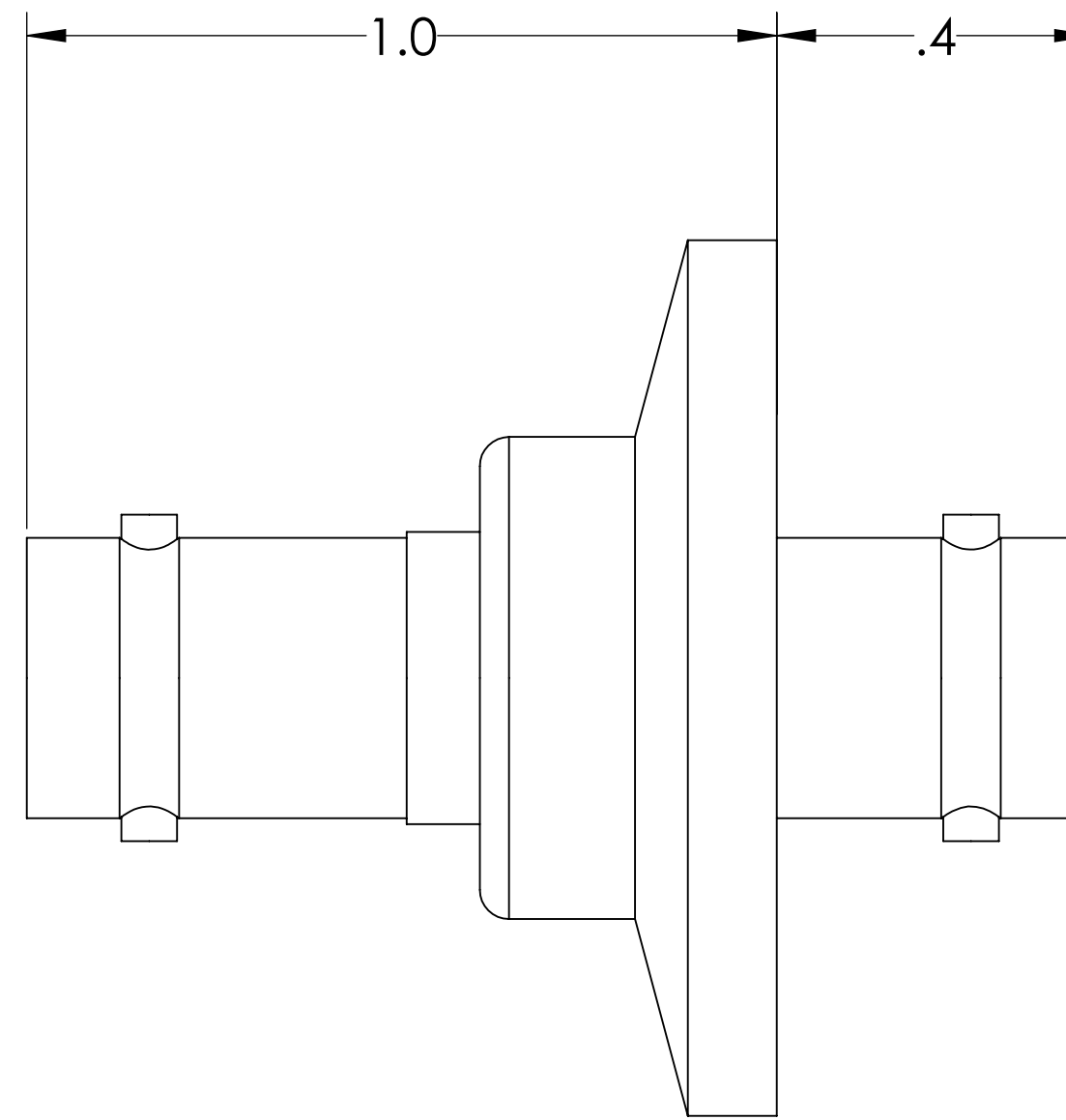
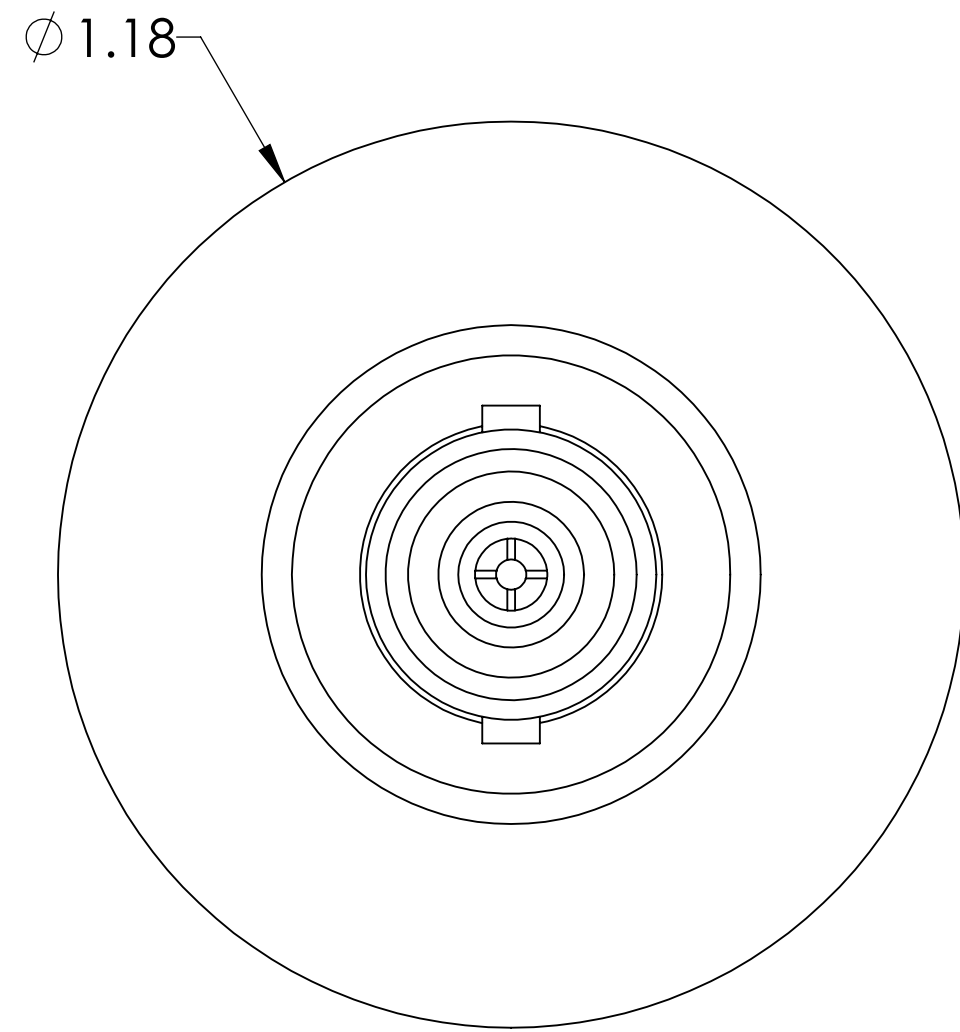

NOTE:

1. SHIELD: GROUNDING
2. VOLTAGE: 500 VOLTS DC
3. CURRENT: N/A
4. TEMPERATURE RATING: -200 TO 450°C (FEEDTHROUGH), 65 TO 165°C (AIRSIDE CONNECTOR)
5. IMPEDANCE: 50 OHM (4 GHz)

BNC Coaxial Feedthrough, 50 Ohm, 1 Pin, 4 GHz, Grounded Shield, 1.18" QF/KF, UHV Compatible

| | | | | | |
|---|--|--------------------------------------|-----------|--|--|
| UNLESS OTHERWISE SPECIFIED: | | QUOTATION # | | N/A | |
| DIMENSIONS ARE IN INCHES TOLERANCES: | | NAME | DATE | MPF PRODUCTS INC. TITLE: BNC COAXIAL FEEDTHROUGH, 50 OHM, 4 GHz, GROUNDING SHIELD, 1.18" QF/KF | |
| ANGULAR: MACH ± 1/2° | | WJ | 9/11/2015 | | |
| TWO PLACE DECIMAL ± .030 | | WJ | 9/11/2015 | | |
| THREE PLACE DECIMAL ± .015 | | WJ | 9/11/2015 | | |
| MATERIAL | | THIRD ANGLE: | | DOWNLOAD FROM MPFPI.COM DWG. NO. A12409-1-QF REV. | |
| FINISH | | | | | |
| PLATING | | APPLICATION: NEXT ASSY USED ON | | | |
| SURFACE FINISH: | | 63/ OR BETTER | | UNLESS OTHERWISE SPECIFIED: ALL DIAMETERS CONCENTRIC WITHIN .005. REMOVE ALL BURRS AND SHARP EDGES | |
| | | Monday, April 8, 2019 2:21:00 PM | | | |