

# MPF PRODUCTS INC.

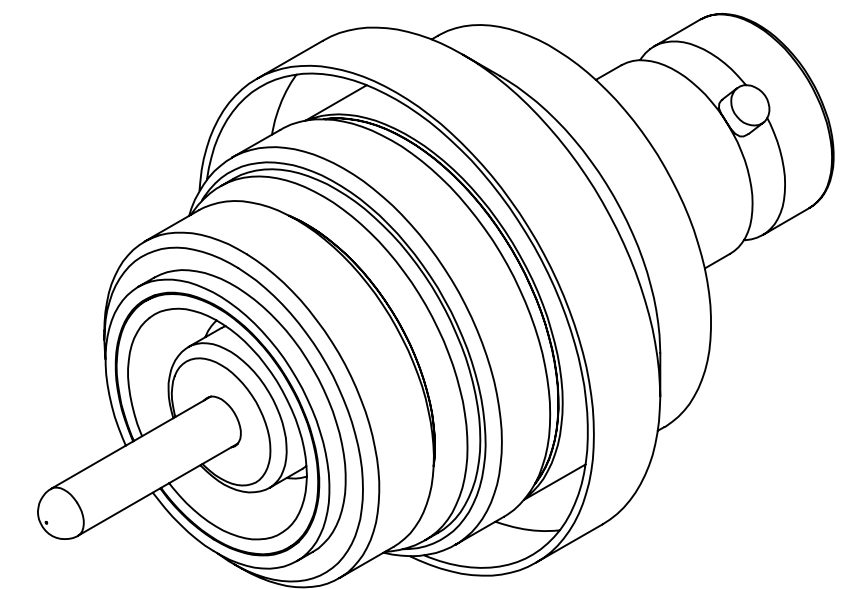

PART #	AIRSIDE CONNECTOR INCLUDED
A1301-1-W	YES
A1301-2-W	NO

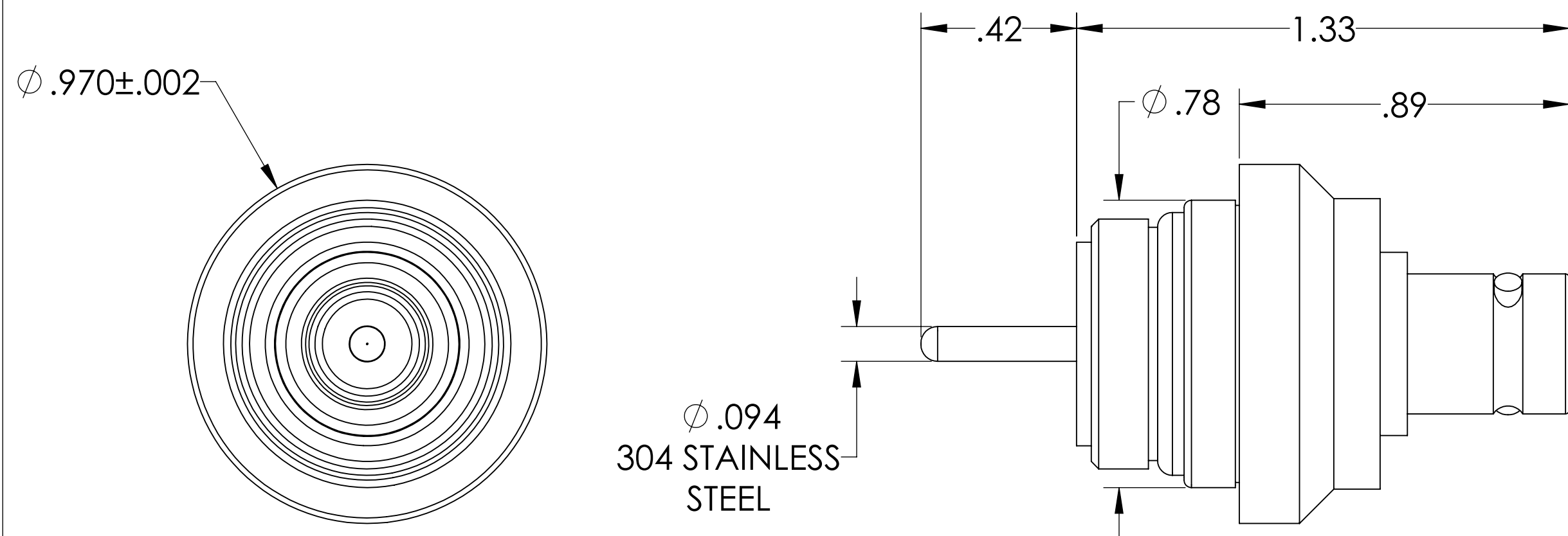
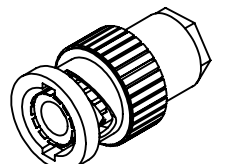

**NOTE:**

1. SHIELD: FLOATING
2. VOLTAGE: 2500 VOLTS DC SHIELD TO GROUND, 500V PIN TO SHEILD
3. CURRENT: 3 AMPS
4. TEMPERATURE RATING: -200 TO 450°C (FEEDTHROUGH), -65 TO 165°C ( AIRSIDE CONNECTOR)
5. IMPEDANCE: NON-CONSTANT

BNC Coaxial Feedthrough, 1 Pins, Floating Shield, 0.970" Dia. 52 Ni-Fe Weld Adapter, UHV Compatible

UNLESS OTHERWISE SPECIFIED:	QUOTATION #	N/A
DIMENSIONS ARE IN INCHES TOLERANCES:	NAME	DATE
ANGULAR: MACH ± 1/2°	WJ	9/11/2015
TWO PLACE DECIMAL ± .030	CHECKED	9/11/2015
THREE PLACE DECIMAL ± .015	ENG APPR.	WJ 9/11/2015
MATERIAL	THIRD ANGLE:	
	APPLICATION	
	NEXT ASSY	USED ON
FINISH	SURFACE FINISH:	63 OR BETTER
PLATING	UNLESS OTHERWISE SPECIFIED:	
	ALL DIAMETERS CONCENTRIC WITHIN .005. REMOVE ALL BURRS AND SHARP EDGES	
TITLE:		MPF PRODUCTS INC.
BNC COAXIAL FEEDTHROUGH, 1 PIN, FLOATING SHIELD, 0.970" 52 NI-FE WELD ADAPTER		
DWG. NO.		A1301 BNC
REV		
DOWNLOADED FROM MPFPI.COM		
Wednesday, March 17, 2021 1:58:30 PM		