

MPF PRODUCTS INC.

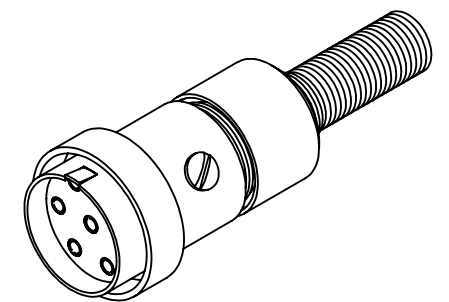
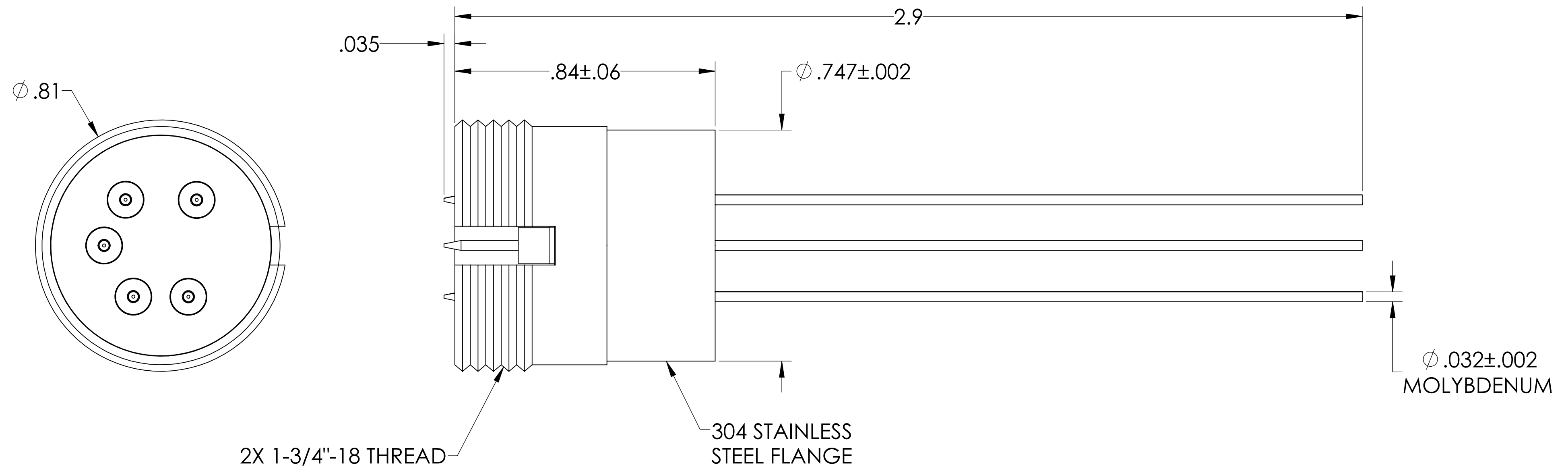
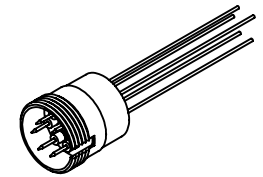

SPECIFICATIONS:

1. VOLTAGE: 500 VOLTS DC
2. CURRENT: 3.5 AMPS PER PIN
3. TEMPERATURE RATING: -100 TO 450°C WITHOUT CONNECTOR
4. LEAK RATE <math> < 1 \times 10^{-9}</math> ATM CC/SEC HE

Multipin Feedthrough, 5 Pins, 500 Volts, 3.5 Amps per Pin, w/ Air-side Connector, 0.747" Weld Adapter

UNLESS OTHERWISE SPECIFIED:		QUOTATION #	
DIMENSIONS ARE IN INCHES TOLERANCES:		N/A	
ANGULAR: MACH $\pm 1/2^\circ$ TWO PLACE DECIMAL $\pm .030$ THREE PLACE DECIMAL $\pm .015$		NAME	DATE
MATERIAL		WJ	9/11/2015
FINISH		CHECKED	9/11/2015
PLATING		ENG APPR.	WJ 9/11/2015
THIRD ANGLE:		TITLE:	
		MULTIPIN, 5 PINS, 500V, 3.5 A, .747" WELD ADAPTER	
APPLICATION		DOWNLOADED FROM MPFPI.COM	
NEXT ASSY		USED ON	DWG. NO.
SURFACE FINISH: $\sqrt{63}$ OR BETTER		REV	
UNLESS OTHERWISE SPECIFIED:		A1424-1-W	
ALL DIAMETERS CONCENTRIC WITHIN .005. REMOVE ALL BURRS AND SHARP EDGES		Tuesday, January 29, 2019 11:22:38 AM	