

MPF PRODUCTS INC.

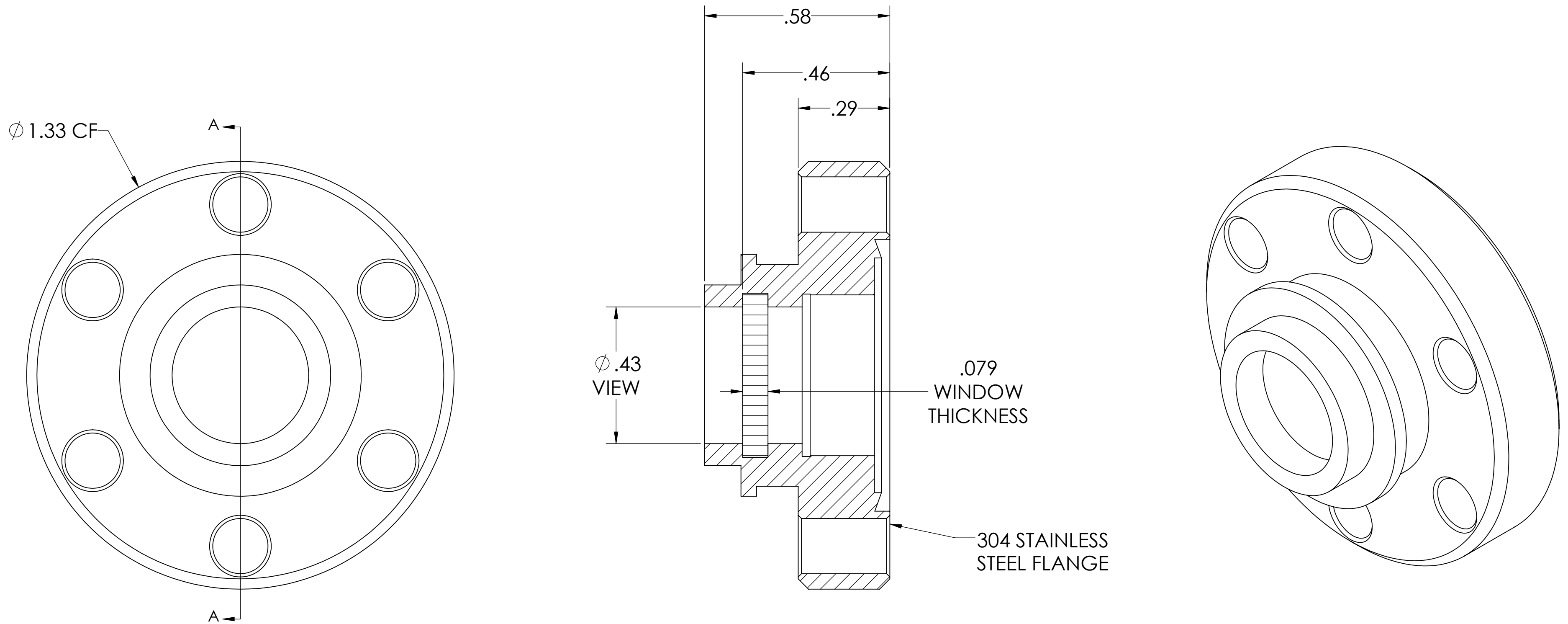

NOTES:

1. MATERIAL: CaF2
2. TWD < 2 WAVES @ 633nm
3. SURFACE FINISH: 40/20 SCRATCH-DIG
4. PARALLELISM < 3 ARC MINUTES
5. THERMAL RANGE: -100°C TO 200°C
6. LEAK RATE < 1 X 10⁻⁹ ATM/CC SEC HE

Calcium Fluoride (CaF2) Viewport, UHV Rated Vacuum Optics, 0.40" View Dia, 1.33" Conflat Flange

UNLESS OTHERWISE SPECIFIED:		QUOTATION #		APPROVED	
DIMENSIONS ARE IN INCHES TOLERANCES:		NAME	DATE	MPF PRODUCTS INC.	
ANGULAR: MACH ± 1/2°		DRAWN	11/14/2015		
TWO PLACE DECIMAL ± .030		CHECKED	11/14/2015		
THREE PLACE DECIMAL ± .015		ENG APPR.	11/14/2015		
MATERIAL		THIRD ANGLE:		VIEWPORT, CaF2, VACUUM OPTICS, 0.40" VIEW, 133CF	
Material <not specified>					
		APPLICATION			
FINISH		SURFACE FINISH:		DOWNLOADED FROM MPFPI.COM	
CONFLAT		63 OR BETTER		DWG. NO.	
PLATING		UNLESS OTHERWISE SPECIFIED:		A14347-1-CF	
		ALL DIAMETERS CONCENTRIC WITHIN .005. REMOVE ALL BURRS AND SHARP EDGES		REV	
		Thursday, July 11, 2019 11:21:26 AM			