

MPF PRODUCTS INC.

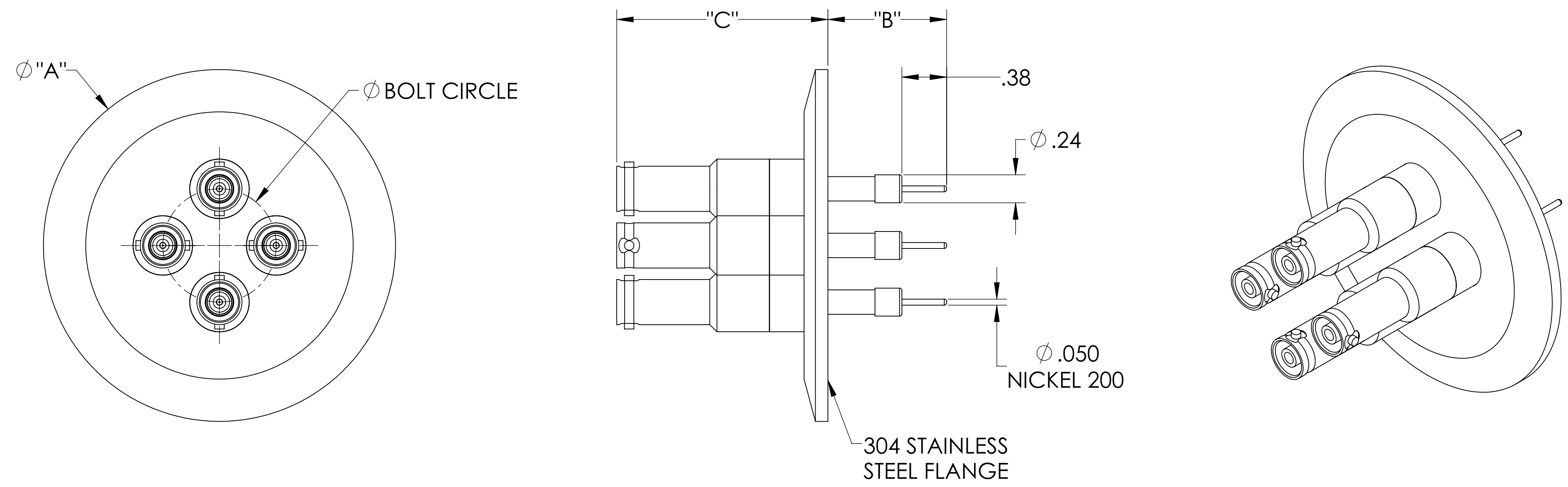

PART #	# OF PINS	Ø "A"	"B"	"C"	BOLT CIRCLE	AIRSIDE CONNECTORS INCLUDED
A1603-1-QF	1	1.18	.9	1.9	OMIT	YES
A1603-1-QF	1	2.16	1.0	1.8	OMIT	YES
A1603-1-QF	2	2.16	1.0	1.8	.75	YES
A1603-1-QF	3	2.95	1.0	1.8	.95	YES
A1603-1-QF	4	2.95	1.0	1.8	.95	YES

NOTE:

1. SHIELD: GROUNDED
2. VOLTAGE: 10,000 VOLTS DC
3. CURRENT: 5 AMPS
4. TEMPERATURE RATING: -200 TO 450°C (FEEDTHROUGH), 65 TO 165°C (AIRSIDE CONNECTOR)
5. IMPEDANCE: NON-CONSTANT

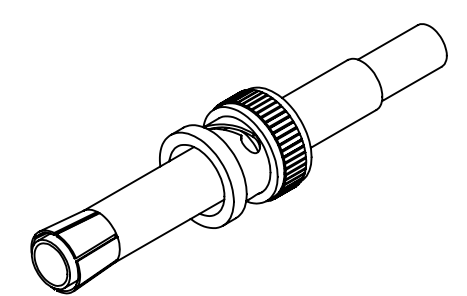

SHV-10 Coaxial Feedthrough, 1/2/3/4 Pin, Grounded Shield, Exposed Insulator, QF/KF, UHV Compatible

UNLESS OTHERWISE SPECIFIED:		QUOTATION #		N/A	
DIMENSIONS ARE IN INCHES TOLERANCES:		NAME	DATE	MPF PRODUCTS INC.	
ANGULAR: MACH ± 1/2°		DRAWN	9/11/2015	TITLE:	
TWO PLACE DECIMAL ± .030		CHECKED	9/11/2015	SHV-10 COAXIAL	
THREE PLACE DECIMAL ± .015		ENG APPR.	9/11/2015	FEEDTHROUGH, 1/2/3/4	
MATERIAL		THIRD ANGLE:		PIN, GROUNDED SHIELD,	
				EXPOSED, QF/KF	
FINISH		APPLICATION		DOWNLOADED FROM MPFPI.COM	
PLATING		NEXT ASSY		DWG. NO.	
		USED ON		REV	
		SURFACE FINISH: 63/ OR BETTER		A1603	
		UNLESS OTHERWISE SPECIFIED:		Monday, January 21, 2019 11:12:55 AM	
		ALL DIAMETERS CONCENTRIC WITHIN .005. REMOVE ALL BURRS AND SHARP EDGES			