

# MPF PRODUCTS INC.

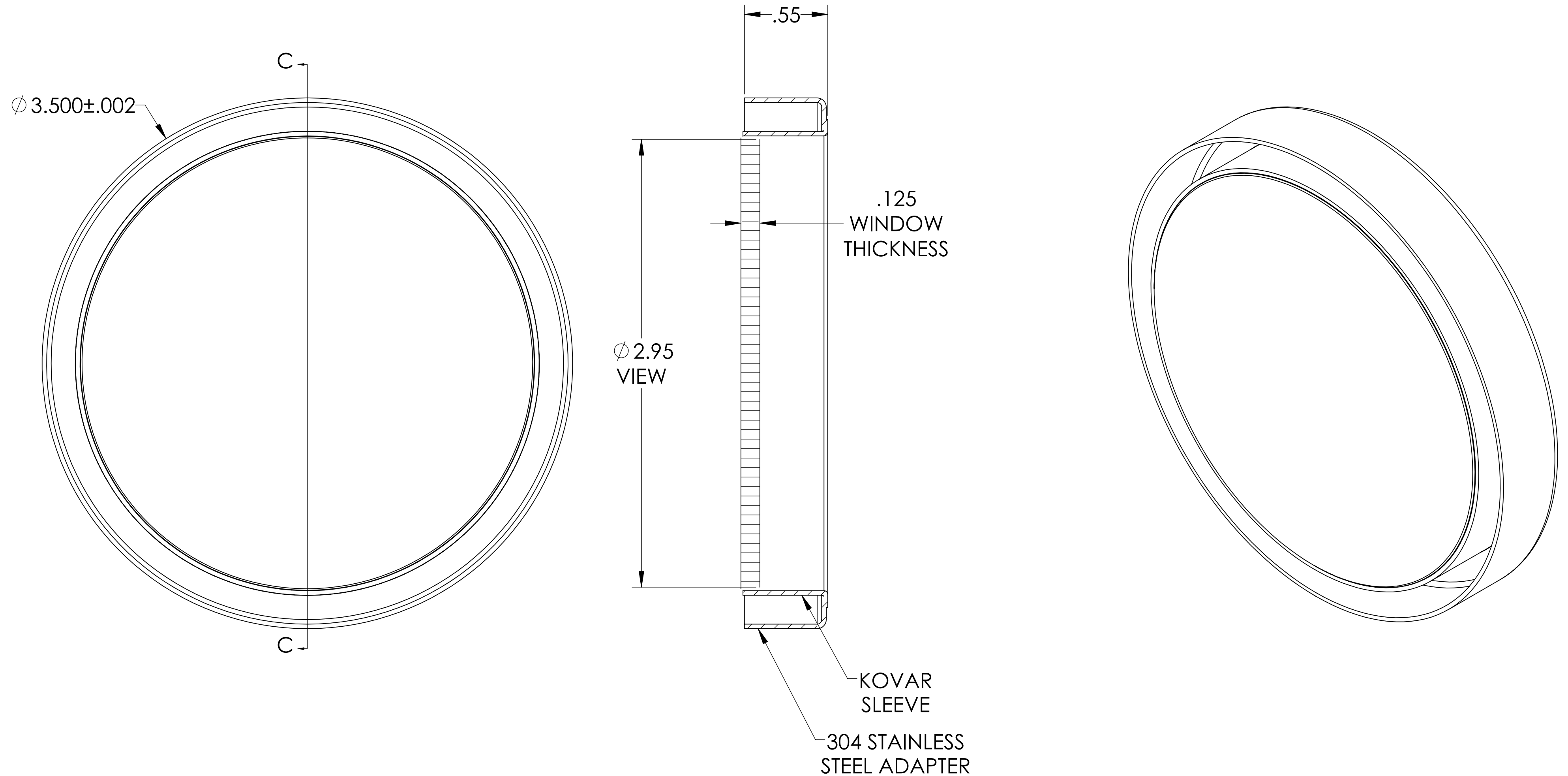

**SPECIFICATIONS:**

1. MATERIAL: SAPPHIRE
2. TWD <math>8\lambda</math> @ 632nm (PEAK TO VALLEY)
3. PARALLELISM <math>3</math> ARC-MINUTES
4. SURFACE FINISH: 50-20 SCRATCH-DIG
5. THERMAL RANGE: -100 °C TO 450 °C
6. ORIENTATION: RANDOM
7. LEAK RATE <math>1 \times 10^{-9}</math> ATM CC/SEC HE

UV Grade Sapphire Viewport, 2.95" View Dia, 3.50" Dia Stainless Steel Weld Adapter

UNLESS OTHERWISE SPECIFIED:	QUOTATION #	N/A	
DIMENSIONS ARE IN INCHES TOLERANCES:	DRAWN	NAME	DATE
ANGULAR: MACH $\pm 1/2^\circ$	WJ	WJ	9/11/2015
TWO PLACE DECIMAL $\pm .030$	CHECKED		9/11/2015
THREE PLACE DECIMAL $\pm .015$	ENG APPR.	WJ	9/11/2015
MATERIAL	THIRD ANGLE:		
FINISH	APPLICATION		
PLATING	NEXT ASSY		
	USED ON		
	SURFACE FINISH: $\sqrt{63}$ OR BETTER		
	UNLESS OTHERWISE SPECIFIED:		
	ALL DIAMETERS CONCENTRIC WITHIN .005. REMOVE ALL BURRS AND SHARP EDGES		
TITLE:		VIEWPORT, SAPPHIRE, UV, 3" VIEW, WELD ADAPTER	
MATERIAL:		MPF PRODUCTS INC.	
MATERIAL:		DOWNLOADED FROM MPFPI.COM	
MATERIAL:		DWG. NO.	REV.
MATERIAL:		A1679-1-W	
MATERIAL:		Thursday, January 24, 2019 11:04:25 AM	