

# MPF PRODUCTS INC.

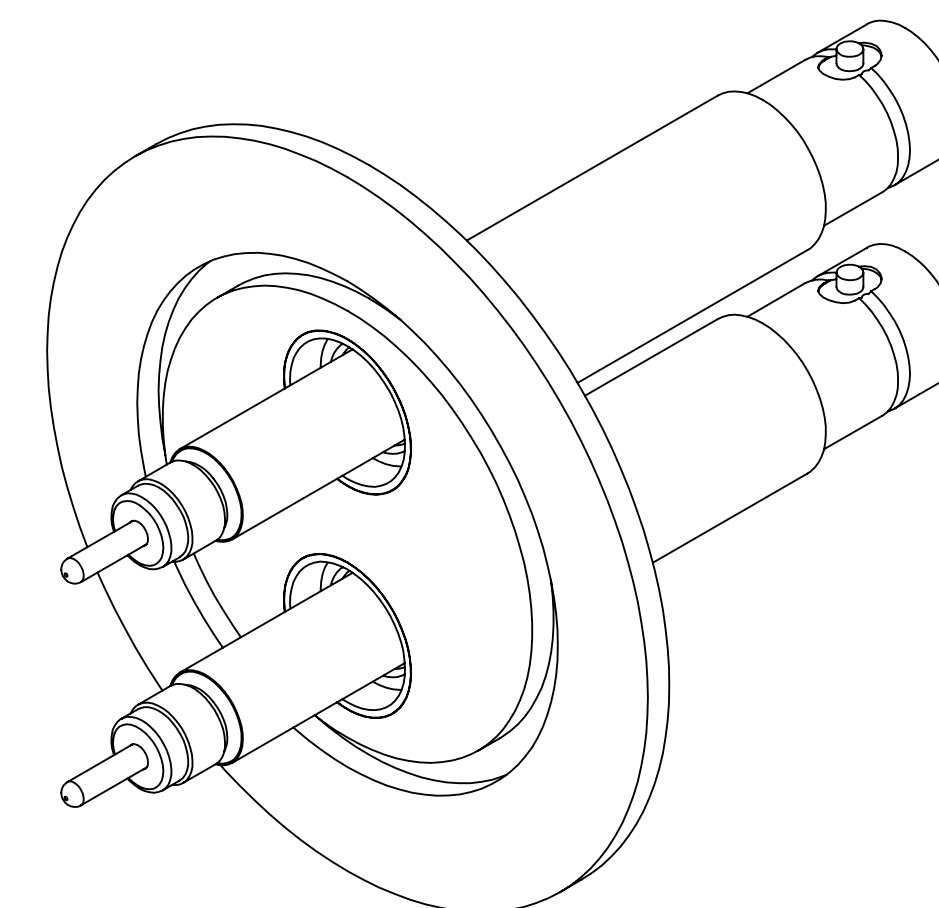

PART #	AIRSIDE CONNECTOR INCLUDED
A2301-1-QF	YES
A2301-2-QF	NO

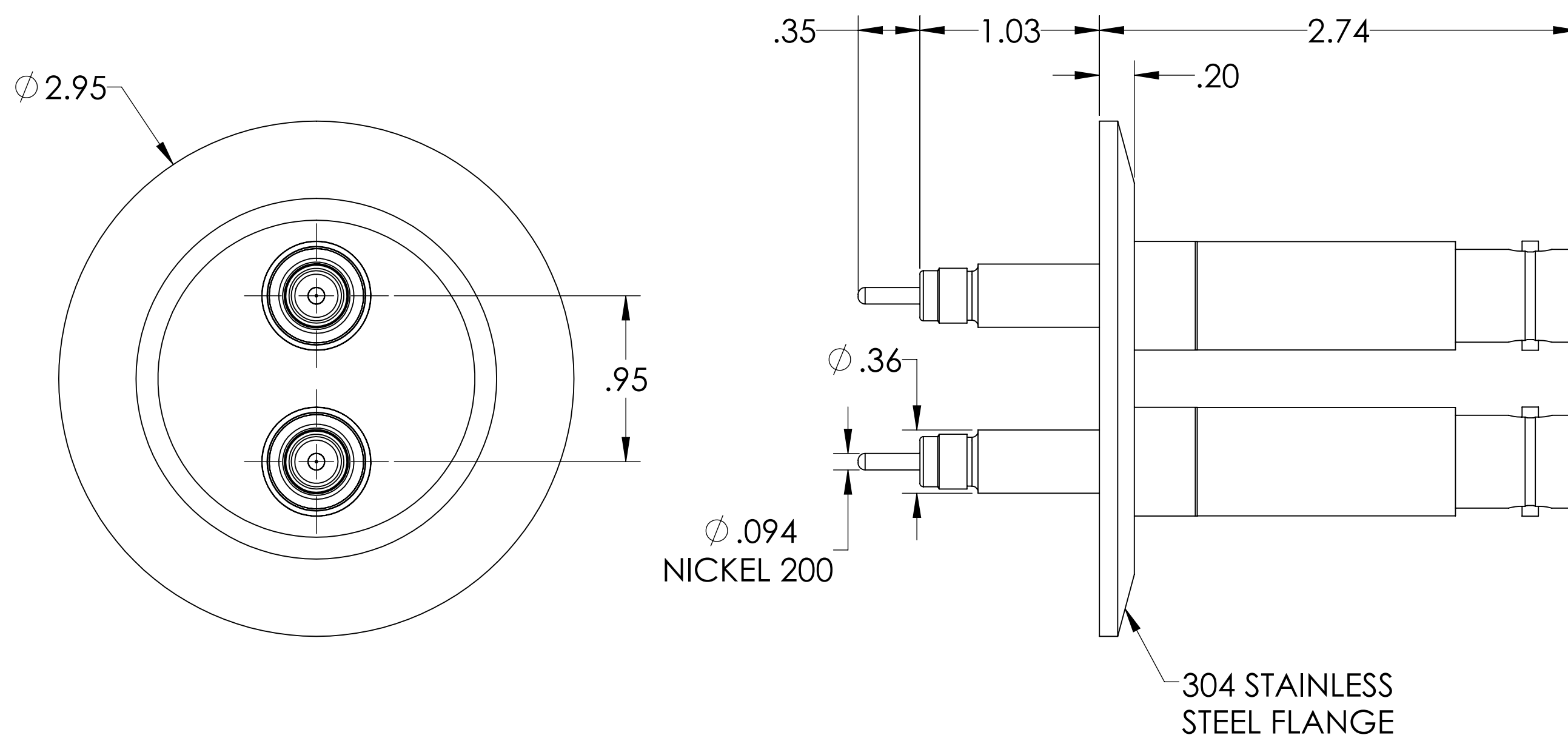
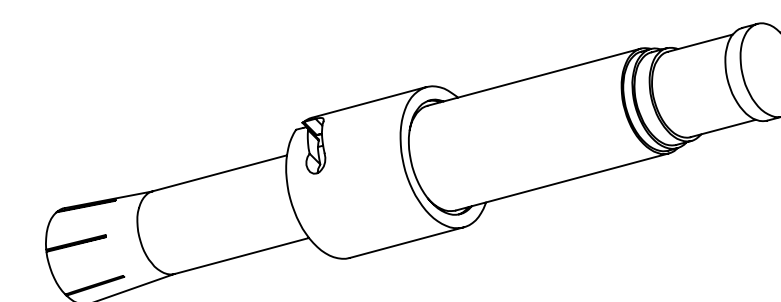

- NOTE:
1. SHIELD: GROUNDED
  2. VOLTAGE: 20,000 VOLTS DC
  3. CURRENT: 15 AMPS
  4. TEMPERATURE RATING: -200 TO 450°C (FEEDTHROUGH), 65 TO 165°C ( AIRSIDE CONNECTOR)
  5. IMPEDANCE: NON-CONSTANT

SHV-20 Coaxial Feedthrough, 2 Pins, Grounded Shield, Exposed Insulator, 2.16" QF/KF, UHV Compatible

UNLESS OTHERWISE SPECIFIED:	QUOTATION #	N/A
DIMENSIONS ARE IN INCHES TOLERANCES:	NAME	DATE
ANGULAR: MACH ± 1/2°	DRAWN	9/11/2015
TWO PLACE DECIMAL ± .030	CHECKED	9/11/2015
THREE PLACE DECIMAL ± .015	ENG APPR.	9/11/2015
MATERIAL	THIRD ANGLE:	
	APPLICATION	
	NEXT ASSY	USED ON
FINISH	SURFACE FINISH:	63 OR BETTER
PLATING	UNLESS OTHERWISE SPECIFIED:	
	ALL DIAMETERS CONCENTRIC WITHIN .005.	
	REMOVE ALL BURRS AND SHARP EDGES	
	TITLE:	SHV-20 COAXIAL FEEDTHROUGH, 2 PINS, GROUNDED SHIELD, EXPOSED, 2.16" QF/KF
	DOWNLOADED FROM MPFPI.COM	
	DWG. NO.	A2301
	REV	
	Friday, January 18, 2019 10:27:49 AM	