

# MPF PRODUCTS INC.

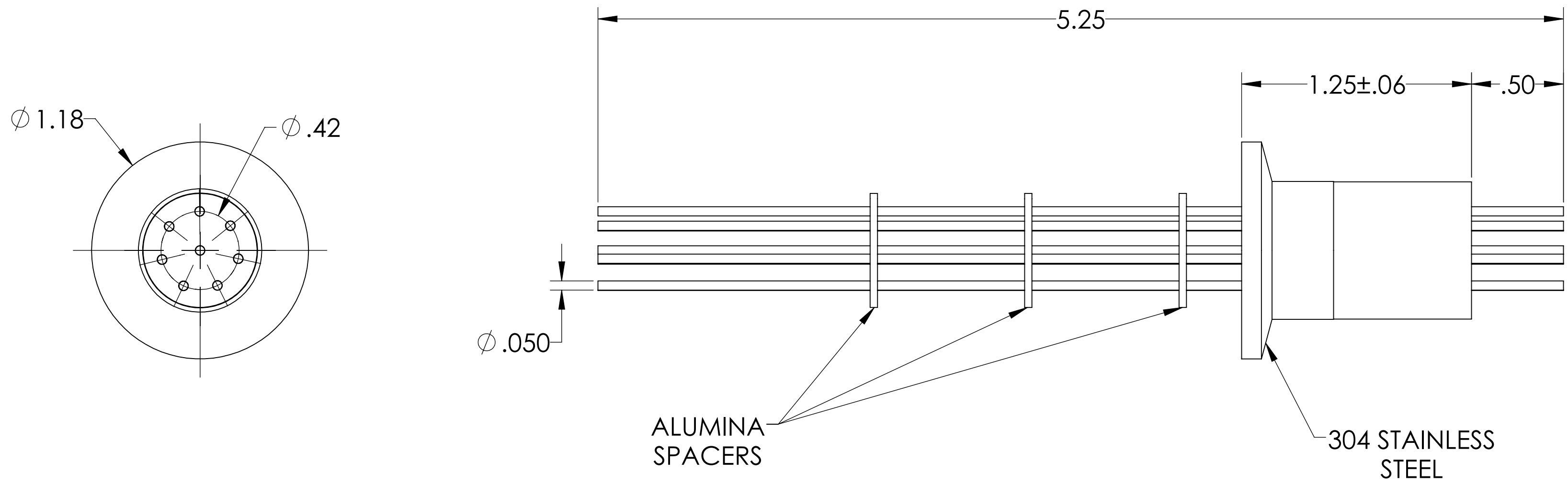
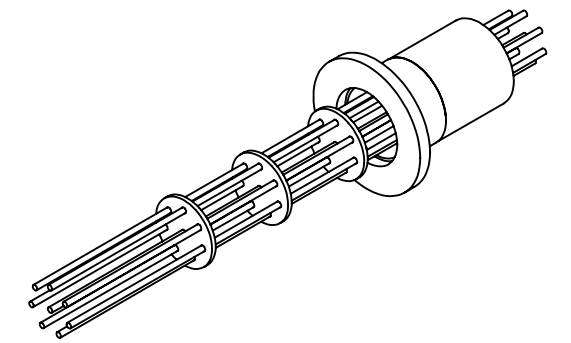

PART #	CONDUCTOR MATERIAL	CURRENT RATING
A2572-1-QF	KOVAR	7 AMPS
A2572-2-QF	MOLYBDENUM	13 AMPS
A2572-3-QF	OFHC COPPER	25 AMPS
A2572-4-QF	NICKEL	8 AMPS
A2572-5-QF	STN STL	1 AMP

- NOTE:
- VOLTAGE: 1000 VOLTS DC
  - CURRENT: SEE TABLE
  - TEMPERATURE RATING: -100 TO 450°C

Power Feedthrough, 1000 Volts, 8 Pins, 0.050" Conductors, 1.18" QF/KF, UHV Rated, Bakeable to 450°C

UNLESS OTHERWISE SPECIFIED:	QUOTATION #	N/A
DIMENSIONS ARE IN INCHES TOLERANCES:	NAME	DATE
ANGULAR: MACH ± 1/2°	DRAWN	9/11/2015
TWO PLACE DECIMAL ± .030	CHECKED	9/11/2015
THREE PLACE DECIMAL ± .015	ENG APPR.	WJ 9/11/2015
MATERIAL	THIRD ANGLE:	
FINISH	APPLICATION	
PLATING	NEXT ASSY USED ON	
	SURFACE FINISH:	63/ OR BETTER
	UNLESS OTHERWISE SPECIFIED:	
	ALL DIAMETERS CONCENTRIC WITHIN .005. REMOVE ALL BURRS AND SHARP EDGES	
TITLE:		MPF PRODUCTS INC.
TITLE:		POWER FEEDTHROUGH, 1000 VOLTS, 8 PIN, 1.18" QF/KF
DWG. NO.		A2572
REV		
DOWNLOADED FROM MPFPI.COM		Tuesday, January 22, 2019 11:38:38 AM