

MPF PRODUCTS INC.

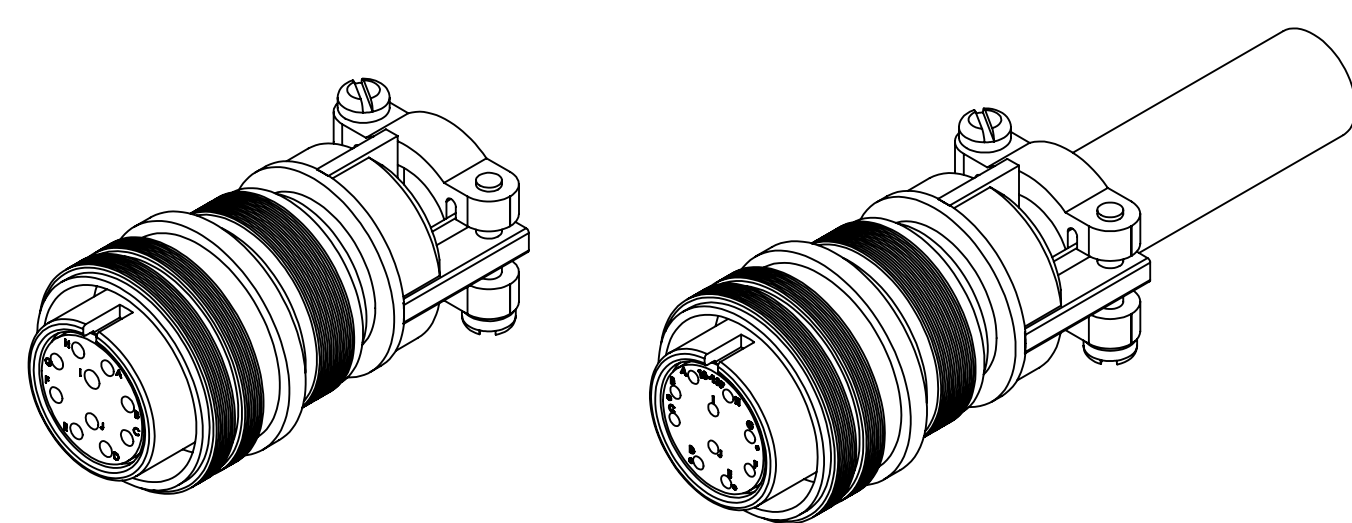
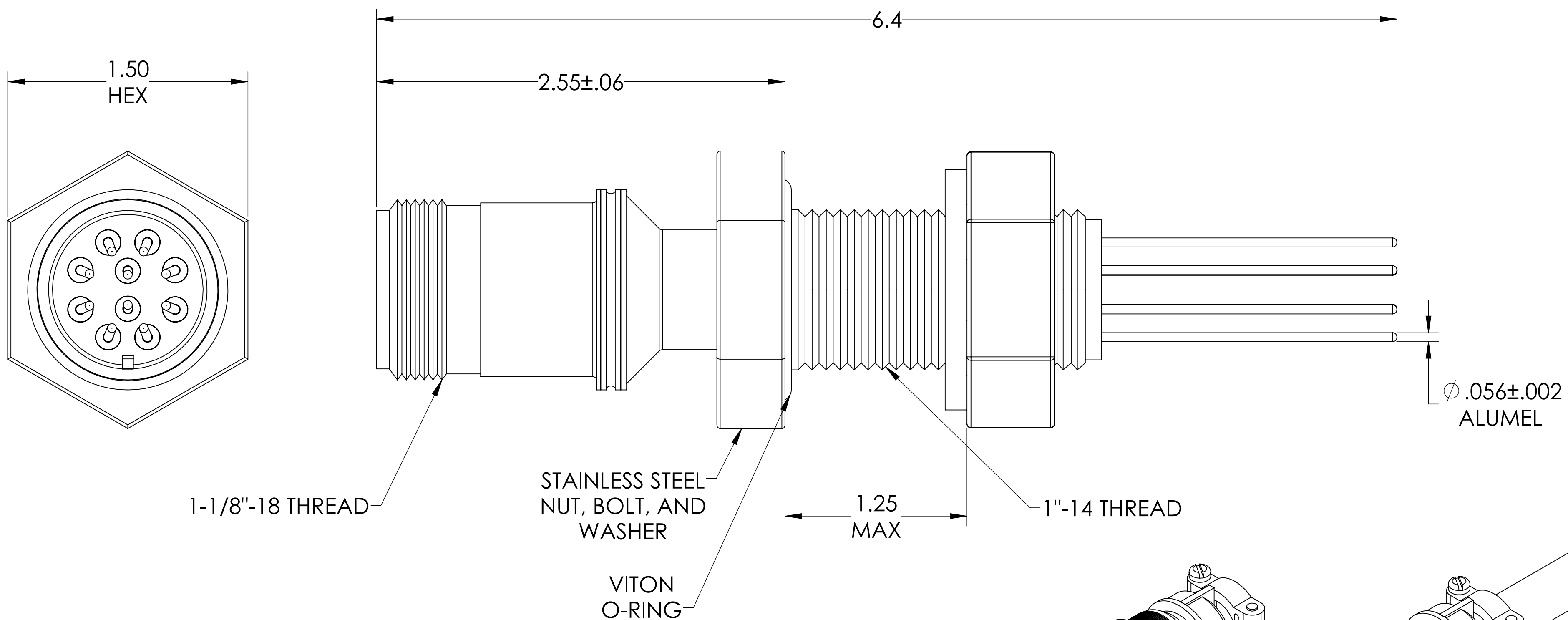
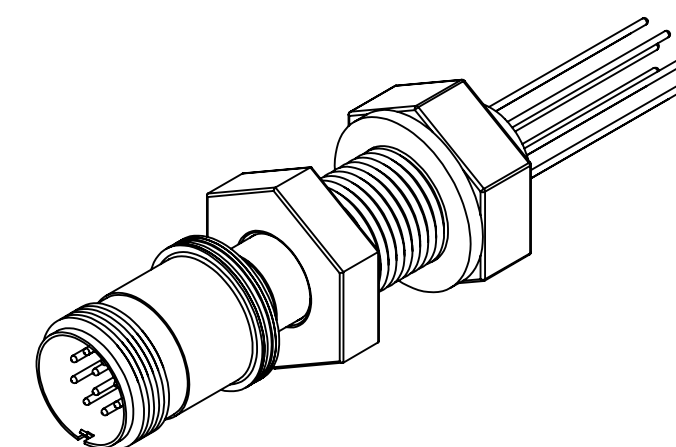

SPECIFICATIONS:

1. VOLTAGE: 700 VOLTS DC
2. CURRENT: 10 AMPS PER PIN, 50 AMPS FULL LOAD
3. TEMPERATURE RATING: -100 TO 450°C WITHOUT CONNECTOR
4. LEAK RATE < 1X10-9 ATM CC/SEC HE

MS Series, Multipin Feedthrough, 10 Pins, 700 Volts, 10 Amps per Pin, w/ Air-side Connector, 1" Baseplate Bolt

UNLESS OTHERWISE SPECIFIED:		QUOTATION #		N/A	
DIMENSIONS ARE IN INCHES TOLERANCES:		NAME	DATE	MPF PRODUCTS INC.	
ANGULAR: MACH ± 1/2°		DRAWN	9/11/2015		
TWO PLACE DECIMAL ± .030		CHECKED	9/11/2015		
THREE PLACE DECIMAL ± .015		ENG APPR.	9/11/2015		
MATERIAL		THIRD ANGLE:		MULTIPIN, 10 PINS, 700V, 10 A, 1" BASEPLATE BOLT	
FINISH		APPLICATION			
PLATING		NEXT ASSY USED ON			
SURFACE FINISH: 63 OR BETTER		SURFACE FINISH: 63 OR BETTER		DOWNLOADED FROM MPFPI.COM	
UNLESS OTHERWISE SPECIFIED:		UNLESS OTHERWISE SPECIFIED:		DWG. NO. A2968-1-BP	
ALL DIAMETERS CONCENTRIC WITHIN .005. REMOVE ALL BURRS AND SHARP EDGES		ALL DIAMETERS CONCENTRIC WITHIN .005. REMOVE ALL BURRS AND SHARP EDGES		REV.	
		Monday, January 28, 2019 11:27:02 AM			