

MPF PRODUCTS INC.

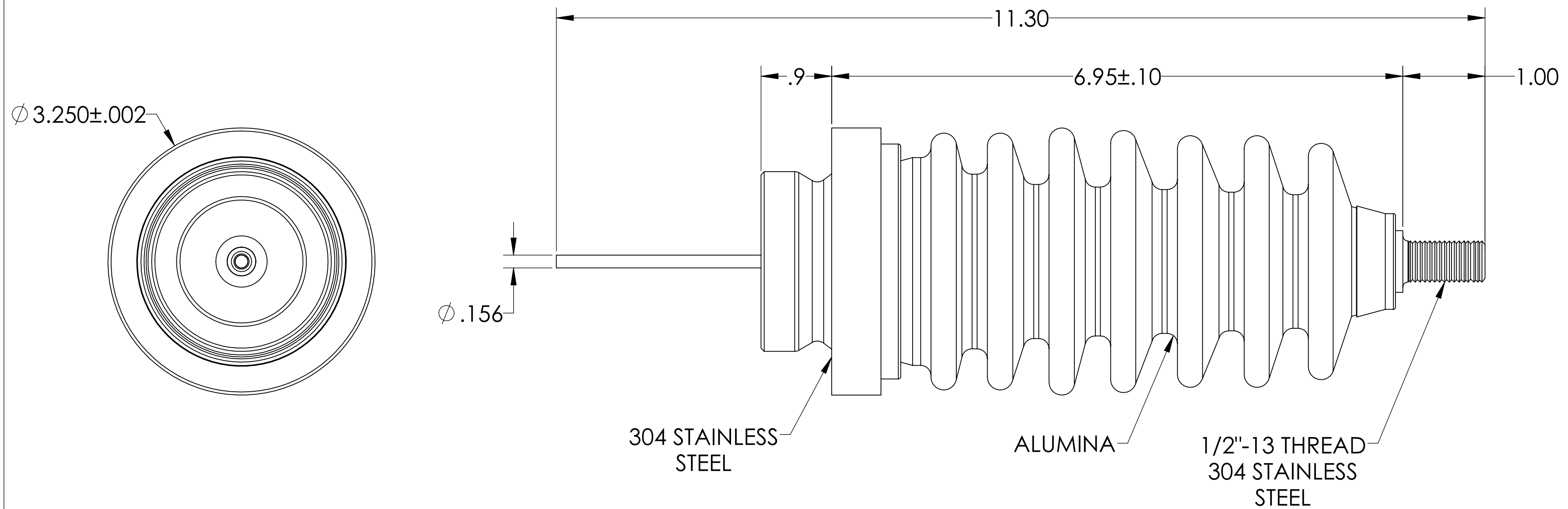
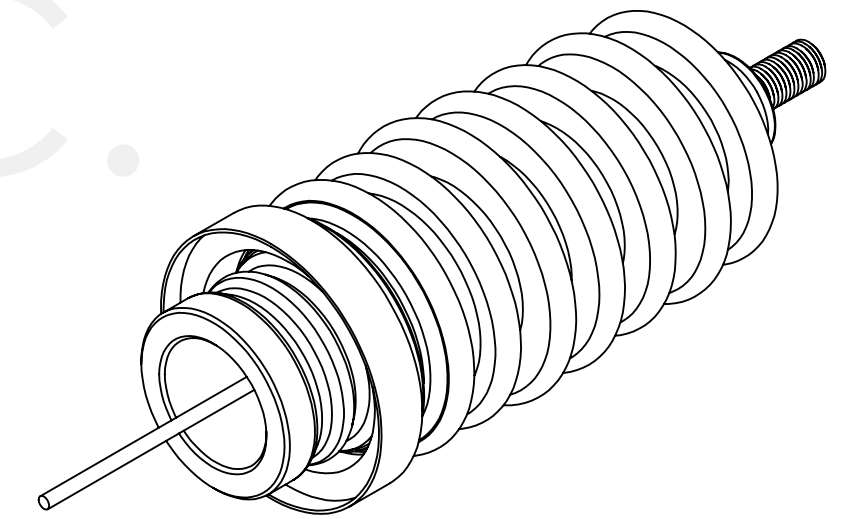

NOTE:

1. VOLTAGE: 60,000 VOLTS DC
2. CURRENT: 6.5 AMPS
3. TEMPERATURE RATING: -100 TO 450°C

Power Feedthrough, 60 KV, 1 Pin, 0.156" Stn. Stl. Conductor, 3.250" Stainless Steel Weld Adapter, UHV Rated, Bakeable to 450°C

UNLESS OTHERWISE SPECIFIED:		QUOTATION #		N/A	
DIMENSIONS ARE IN INCHES TOLERANCES:		NAME	DATE	MPF PRODUCTS INC.	
ANGULAR: MACH $\pm 1/2^\circ$		DRAWN	9/11/2015		
TWO PLACE DECIMAL $\pm .030$		CHECKED	9/11/2015		
THREE PLACE DECIMAL $\pm .015$		ENG APPR.	9/11/2015		
MATERIAL		THIRD ANGLE:		POWER FEEDTHROUGH, 60 KV, 1 PIN, 3.250" WELD ADAPTER	
FINISH		APPLICATION			
PLATING		NEXT ASSY USED ON			
SURFACE FINISH:		SURFACE FINISH: $\sqrt{63}$ OR BETTER		DOWNLOADED FROM MPFPI.COM	
UNLESS OTHERWISE SPECIFIED:		UNLESS OTHERWISE SPECIFIED:		DWG. NO. A3106-1-W	
ALL DIAMETERS CONCENTRIC WITHIN .005. REMOVE ALL BURRS AND SHARP EDGES		ALL DIAMETERS CONCENTRIC WITHIN .005. REMOVE ALL BURRS AND SHARP EDGES		REV	
				Monday, June 10, 2019 2:27:41 PM	