

MPF PRODUCTS INC.

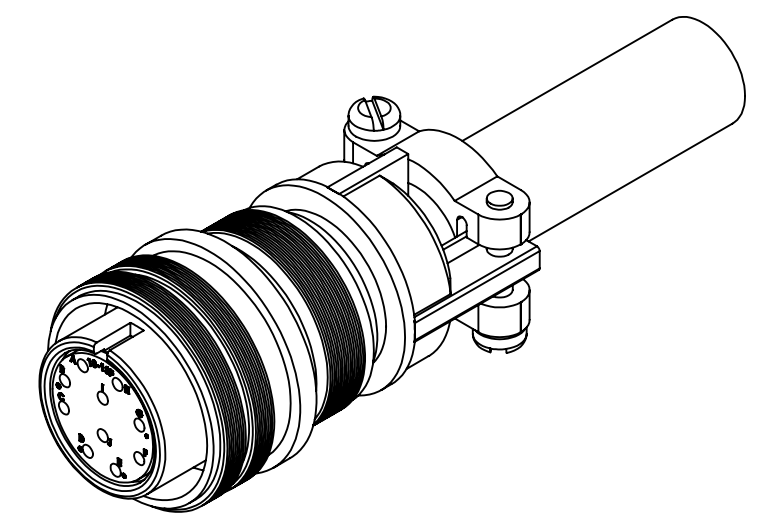
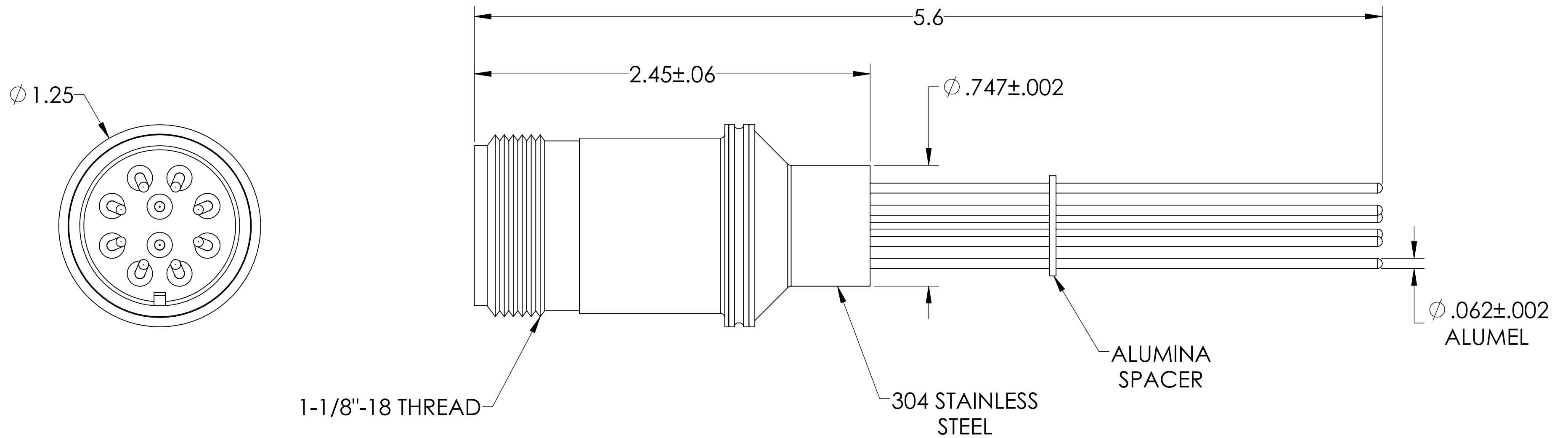
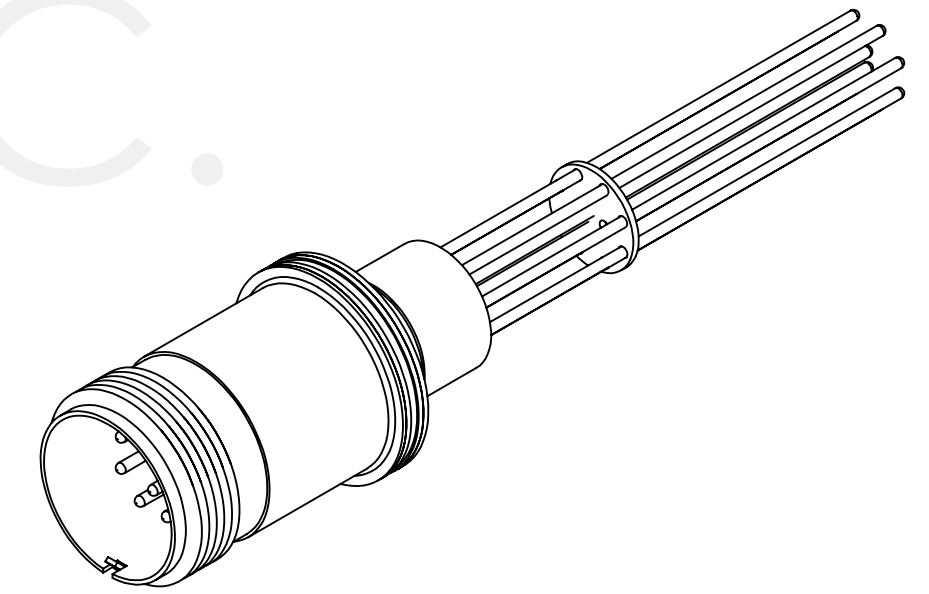

SPECIFICATIONS:

1. VOLTAGE: 700 VOLTS DC
2. CURRENT: 10 AMPS PER PIN, 50 AMPS FULL LOAD
3. TEMPERATURE RATING: -100 TO 450°C WITHOUT CONNECTOR
4. LEAK RATE < 1X10-9 ATM CC/SEC HE

MS Series, Multipin Feedthrough, 10 Pins, 700 Volts, 10 Amps per Pin, 0.062" Dia Conductors w/ Air-side Connector, 0.75" Weld Adapter

| | | | | | |
|---|--|---|------|---------------------------|--|
| UNLESS OTHERWISE SPECIFIED: | | QUOTATION # | | N/A | |
| DIMENSIONS ARE IN INCHES TOLERANCES: | | NAME | DATE | MPF PRODUCTS INC. | |
| ANGULAR: MACH ± 1/2° | | DRAWN | WJ | 9/11/2015 | TITLE: MULTIPIN, 10 PINS, 700V, 10A, .747" WELD ADAPTER |
| TWO PLACE DECIMAL ± .030 | | CHECKED | | 9/11/2015 | |
| THREE PLACE DECIMAL ± .015 | | ENG APPR. | WJ | 9/11/2015 | |
| MATERIAL | | THIRD ANGLE: | | APPLICATION | |
| | | | | NEXT ASSY USED ON | |
| FINISH | | SURFACE FINISH: | | DOWNLOADED FROM MPFPI.COM | |
| PLATING | | UNLESS OTHERWISE SPECIFIED: | | DWG. NO. | |
| | | ALL DIAMETERS CONCENTRIC WITHIN .005. REMOVE ALL BURRS AND SHARP EDGES | | A3527-1-W | |
| | | Monday, January 28, 2019 1:53:41 PM | | REV | |