

MPF PRODUCTS INC.

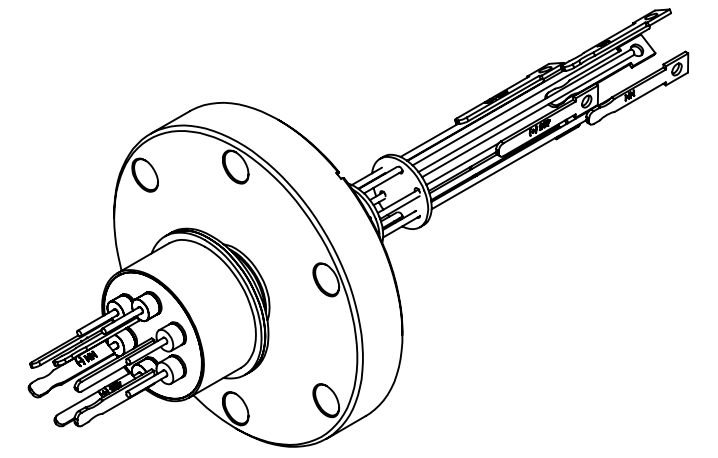

Ø 2.75 CF

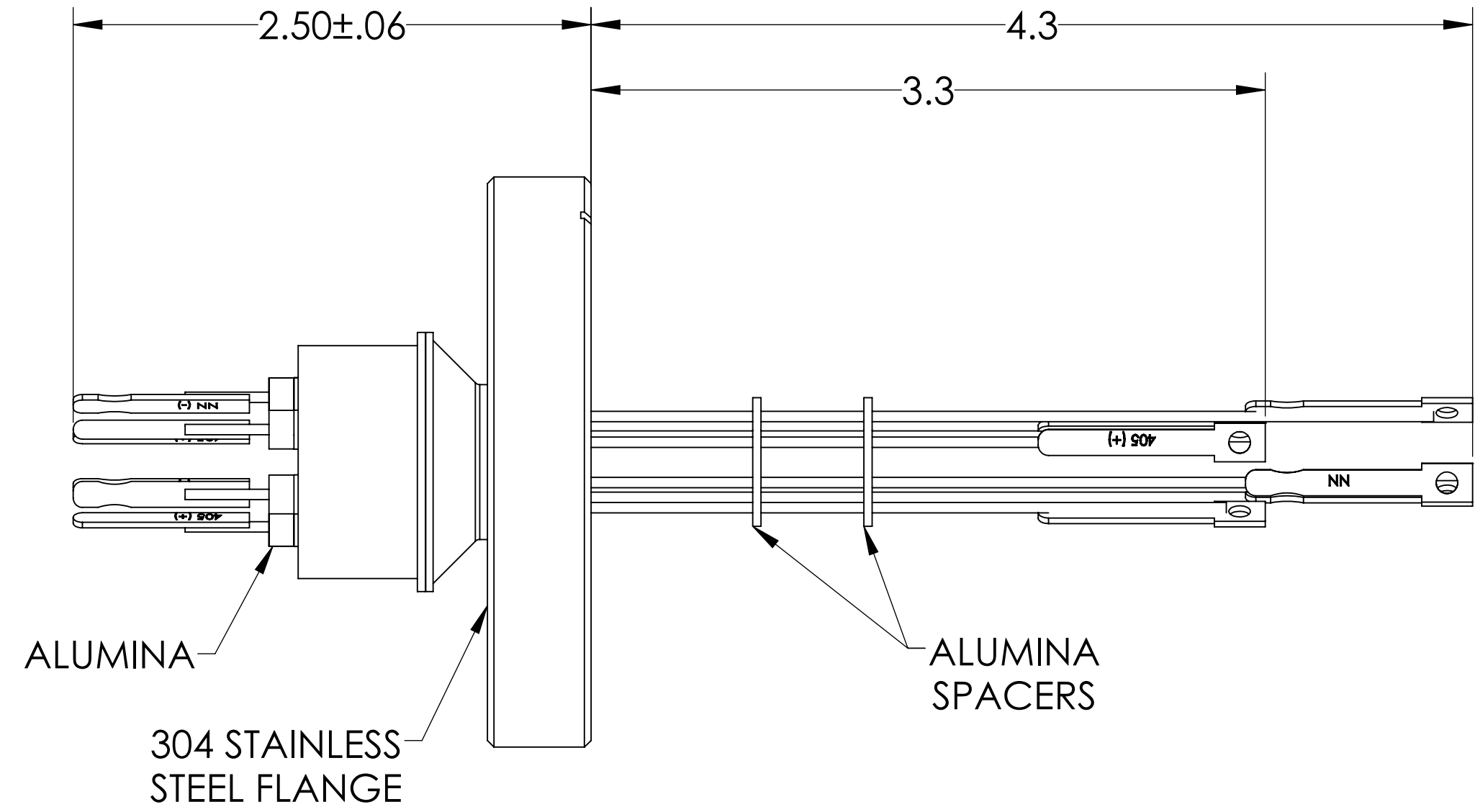
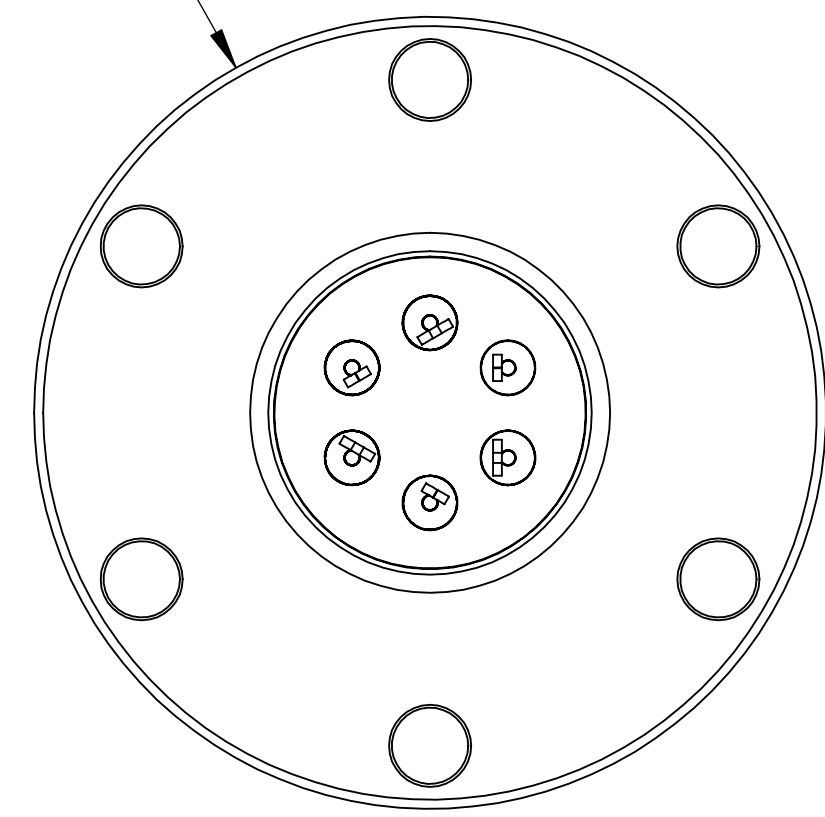

PART #	T/C TYPE
A5775-1-CF	K
A5775-2-CF	J
A5775-3-CF	E
A5775-4-CF	C

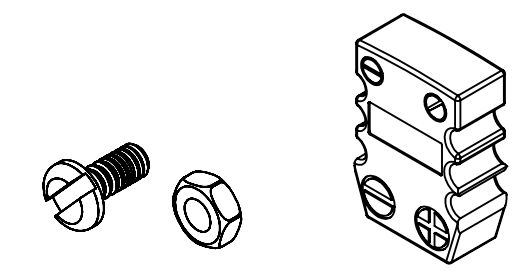

- SPECIFICATIONS:**
1. TEMPERATURE RATING: -100 TO 450°C
 2. LEAK RATE < 1X10-9 ATM CC/SEC HE

Thermocouple Feedthrough, 3 Pairs, Miniature Connector, 2.75" Conflat Flange

UNLESS OTHERWISE SPECIFIED:		QUOTATION #		N/A	
DIMENSIONS ARE IN INCHES TOLERANCES:		NAME	DATE	MPF PRODUCTS INC.	
ANGULAR: MACH ± 1/2°		DRAWN	9/11/2015		
TWO PLACE DECIMAL ± .030		CHECKED	9/11/2015		
THREE PLACE DECIMAL ± .015		ENG APPR.	9/11/2015		
MATERIAL		THIRD ANGLE:		THERMOCOUPLE, 3 PAIRS, CONNECTOR, 275CF	
		APPLICATION			
FINISH		NEXT ASSY	USED ON	DOWNLOADED FROM MPFPI.COM	
PLATING		SURFACE FINISH: 63/ OR BETTER		DWG. NO.	REV
		UNLESS OTHERWISE SPECIFIED:		A5775	
		ALL DIAMETERS CONCENTRIC WITHIN .005. REMOVE ALL BURRS AND SHARP EDGES		Friday, February 8, 2019 1:12:20 PM	