

MPF PRODUCTS INC.

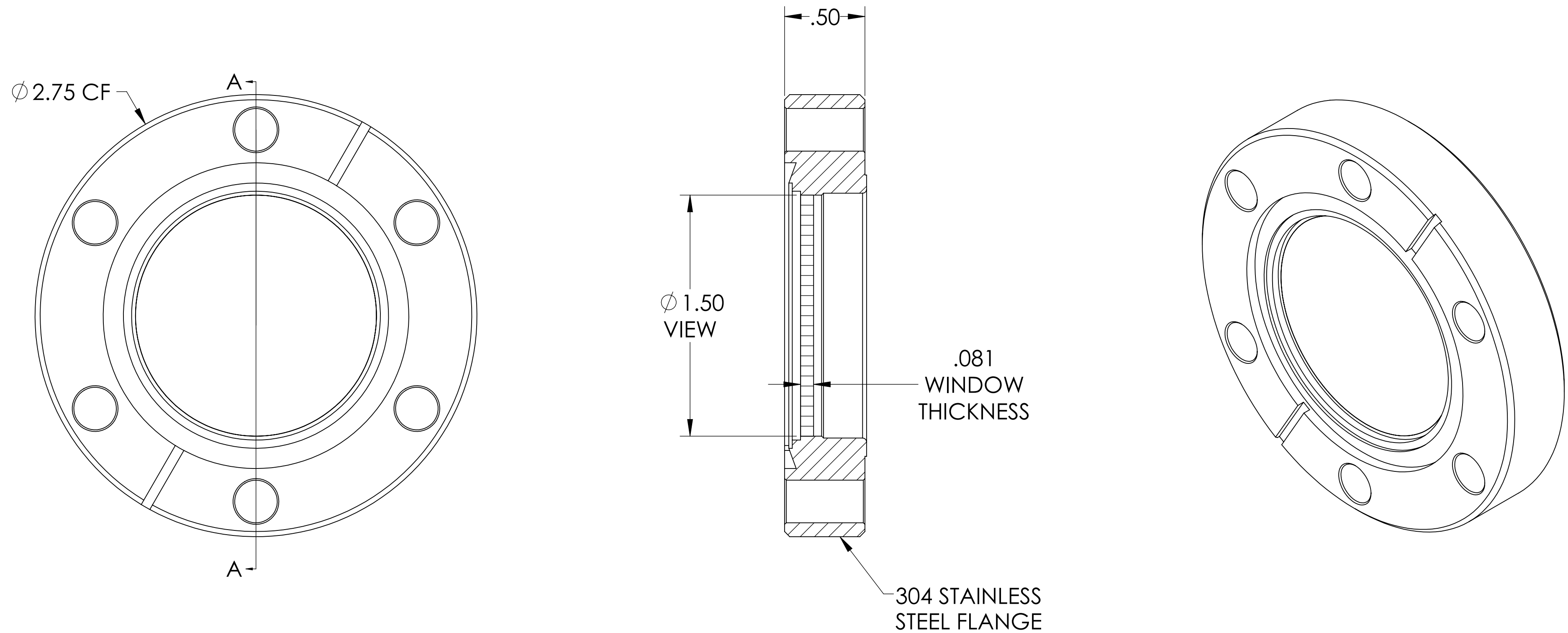

SPECIFICATIONS:

1. MATERIAL: CORNING HPFS 7980 FUSED SILICA
2. TWD <math>< 10\lambda</math> @ 632NM (PEAK TO VALLEY)
3. SURFACE FINISH: 40/20 SCRATCH-DIG
4. PARALLELISM <math>< 30</math> ARC MINUTES
5. THERMAL RANGE: -100 °C TO 200 °C
6. HOMOGENEITY GRADE: F
7. INCLUSION CLASS: 2
8. LEAK RATE <math>< 1 \times 10^{-9}</math> ATM-CC/SEC HE

UV Grade Sapphire Viewport, 1.44" View Dia, 2.75" Conflat Flange

UNLESS OTHERWISE SPECIFIED:	QUOTATION #		N/A
DIMENSIONS ARE IN INCHES TOLERANCES:	DRAWN	WJ	9/11/2015
ANGULAR: MACH $\pm 1/2^\circ$	CHECKED	WJ	9/11/2015
TWO PLACE DECIMAL $\pm .030$	ENG APPR.	WJ	9/11/2015
THREE PLACE DECIMAL $\pm .015$	THIRD ANGLE:		
MATERIAL	APPLICATION		
	NEXT ASSY	USED ON	
FINISH	SURFACE FINISH: $\sqrt{63}$ OR BETTER		
PLATING	UNLESS OTHERWISE SPECIFIED:		
	ALL DIAMETERS CONCENTRIC WITHIN .005. REMOVE ALL BURRS AND SHARP EDGES		
MPF PRODUCTS INC.			TITLE:
			VIEWPORT, SAPPHIRE, UV, 1.4" VIEW, 275CF
DOWNLOADED FROM MPFPI.COM			DWG. NO.
			A6944-1-CF
			REV
			Thursday, January 24, 2019 11:32:19 AM