

# MPF PRODUCTS INC.

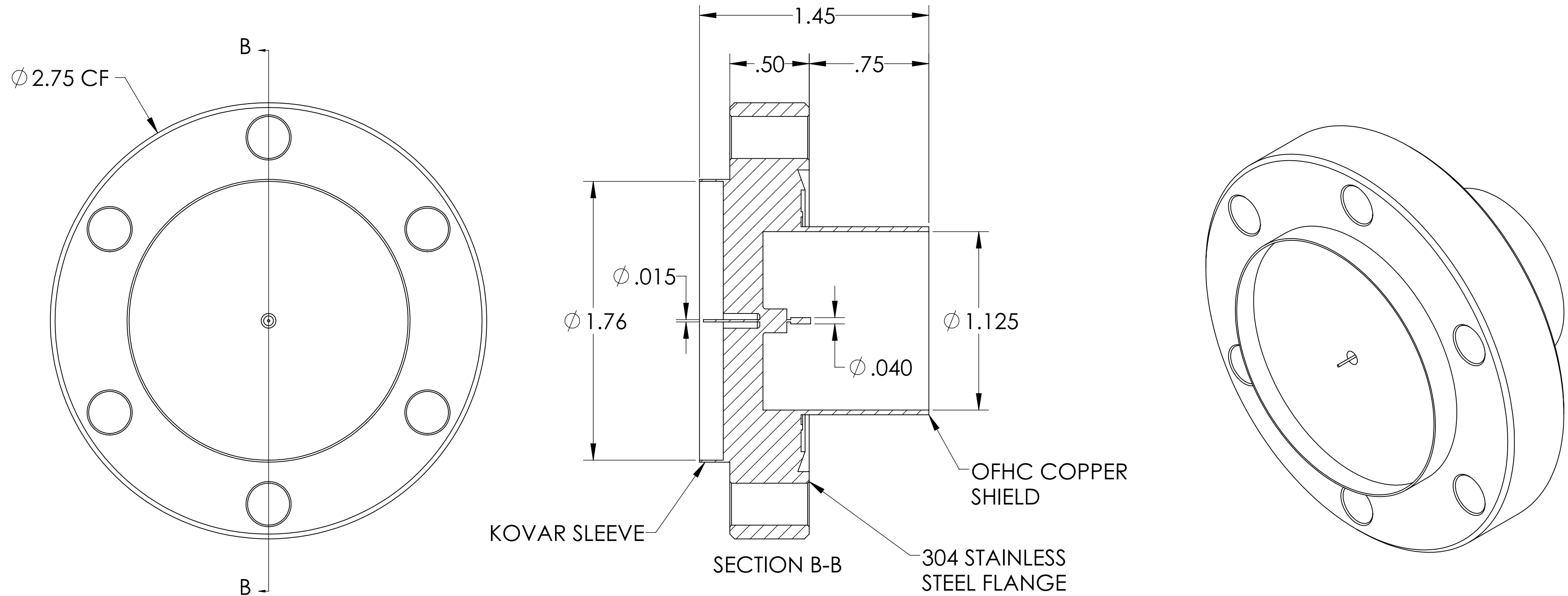

**NOTE:**

1. SHIELD: FLOATING
2. VOLTAGE: 5000 VOLTS DC
3. CURRENT: 5 AMPS
4. TEMPERATURE RATING: -200 TO 450°C (FEEDTHROUGH), 65 TO 165°C (AIRSIDE CONNECTOR)
5. MATCHED IMPEDANCE: 200 OHM

200 Ohm Coaxial Feedthrough, 1 Pin, Floating Shield, 2.75" Conflat Flange, UHV Compatible

UNLESS OTHERWISE SPECIFIED:		QUOTATION #		N/A		
DIMENSIONS ARE IN INCHES		NAME	DATE	MPF PRODUCTS INC.		
TOLERANCES:		DRAWN	WJ			9/11/2015
ANGULAR: MACH ± 1/2°		CHECKED	WJ			9/11/2015
TWO PLACE DECIMAL ± .030		ENG APPR.	WJ			9/11/2015
THREE PLACE DECIMAL ± .015		THIRD ANGLE:		TITLE: <b>200 OHM COAXIAL                  FEEDTHROUGH FLOATING                  SHIELD 275CF</b>		
MATERIAL						
FINISH		APPLICATION NEXT ASSY      USED ON				
PLATING		SURFACE FINISH: 63 OR BETTER		DOWNLOADED FROM MPFPI.COM DWG. NO.      REV		
		UNLESS OTHERWISE SPECIFIED:		A10892-1-CF		
		ALL DIAMETERS CONCENTRIC WITHIN .005. REMOVE ALL BURRS AND SHARP EDGES		Monday, July 15, 2019 2:50:20 PM		