

MPF PRODUCTS INC.

FIBER CONSTRUCTION

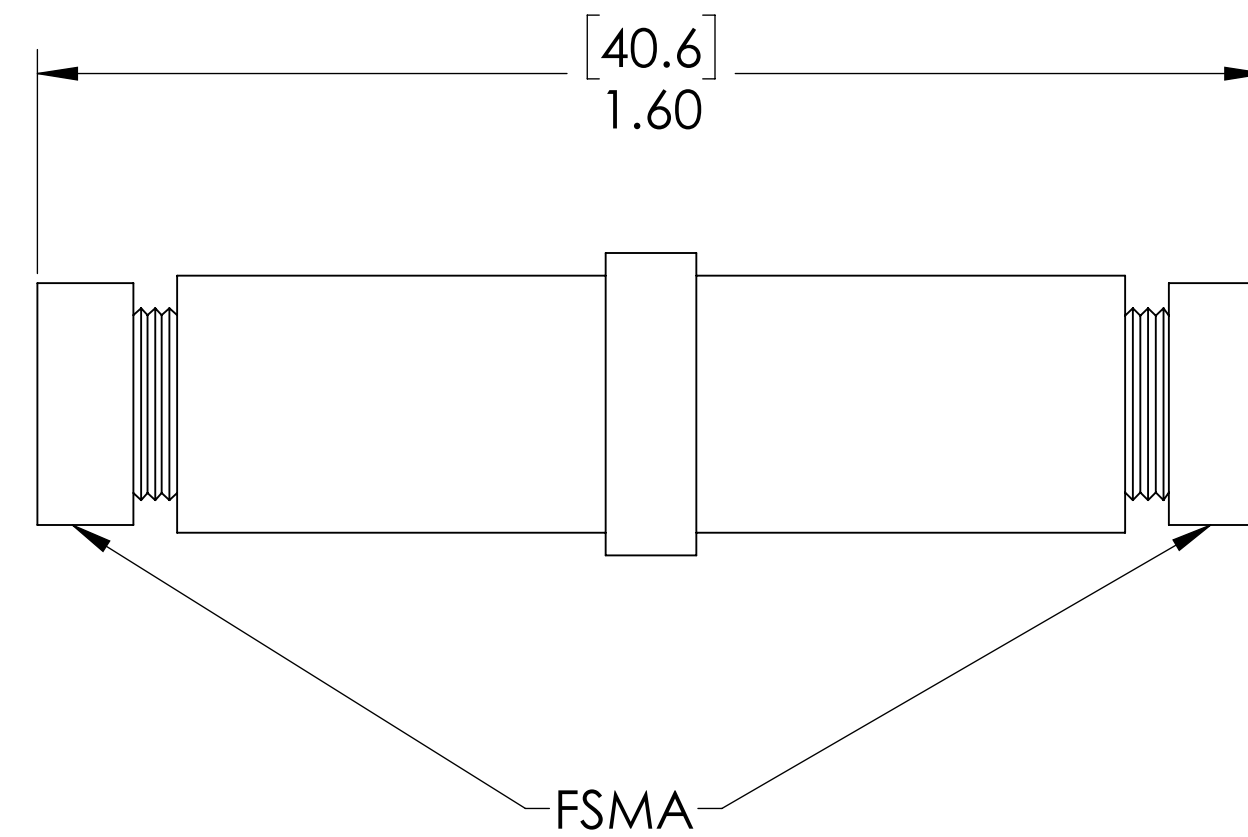
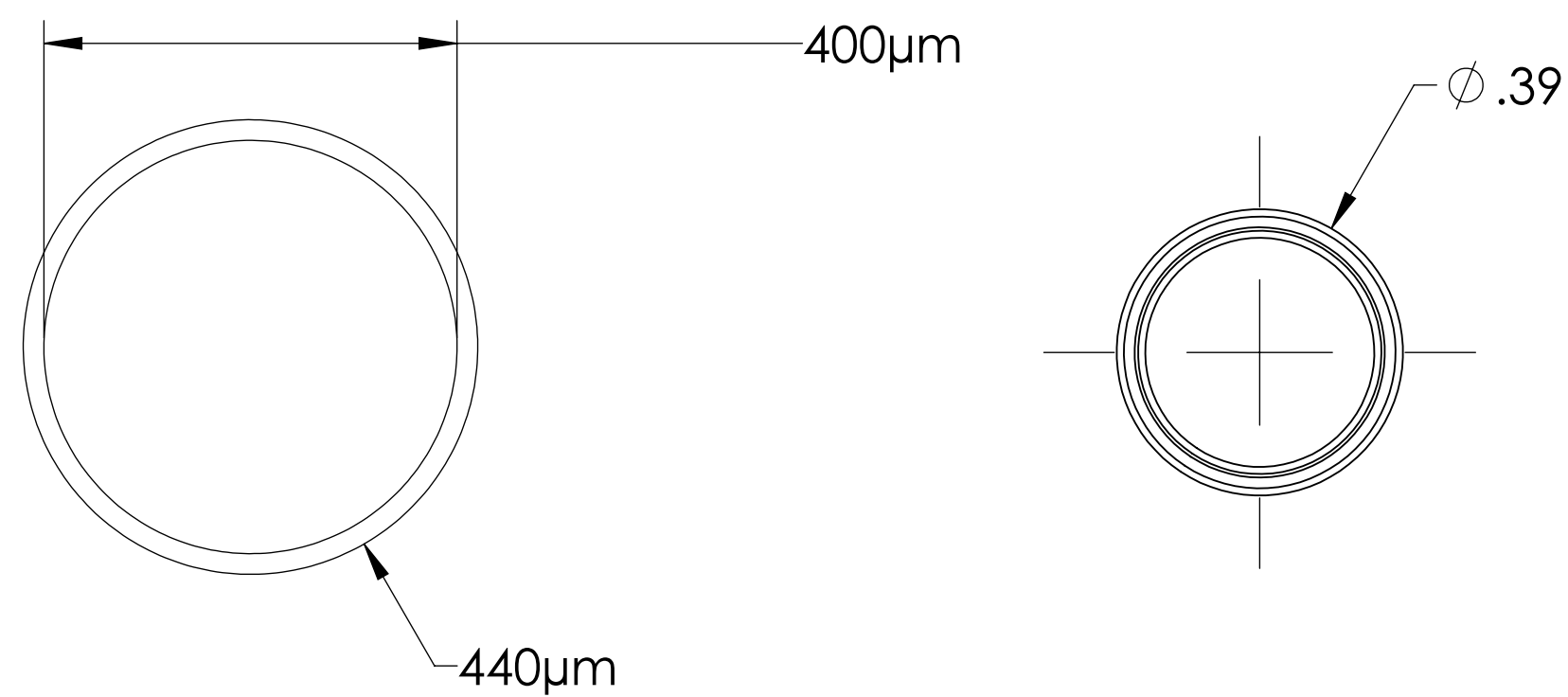

MM400 UV FSMA NOTES:

1. WAVELENGTH: 190 TO 1100nm
2. NUMERICAL APERATURE: 0.22
3. TYPICAL INSERTION LOSS: 1.2dB
4. FERRULE: 2.5mm CERAMICS (ZrO2)

Multimode (MM400) UV Fiber Optic Feedthrough, FSMA Connector

UNLESS OTHERWISE SPECIFIED:		QUOTATION #		N/A	
DIMENSIONS ARE IN INCHES TOLERANCES:		NAME	DATE	MPF PRODUCTS INC.	
ANGULAR: MACH ± 1/2°		DRAWN	9/11/2015		
TWO PLACE DECIMAL ± .030		CHECKED	9/11/2015		
THREE PLACE DECIMAL ± .015		ENG APPR.	9/11/2015		
MATERIAL		THIRD ANGLE:		TITLE: MULTIMODE FIBER OPTIC FEEDTHROUGH (FIBER MM400)	
		APPLICATION			
FINISH		SURFACE FINISH: 63 OR BETTER		DOWNLOADED FROM MPFPI.COM DWG. NO.	
PLATING		UNLESS OTHERWISE SPECIFIED:		A14873-47-W	
		ALL DIAMETERS CONCENTRIC WITHIN .005. REMOVE ALL BURRS AND SHARP EDGES		REV Friday, July 26, 2019 10:40:23 AM	