

# MPF PRODUCTS INC.

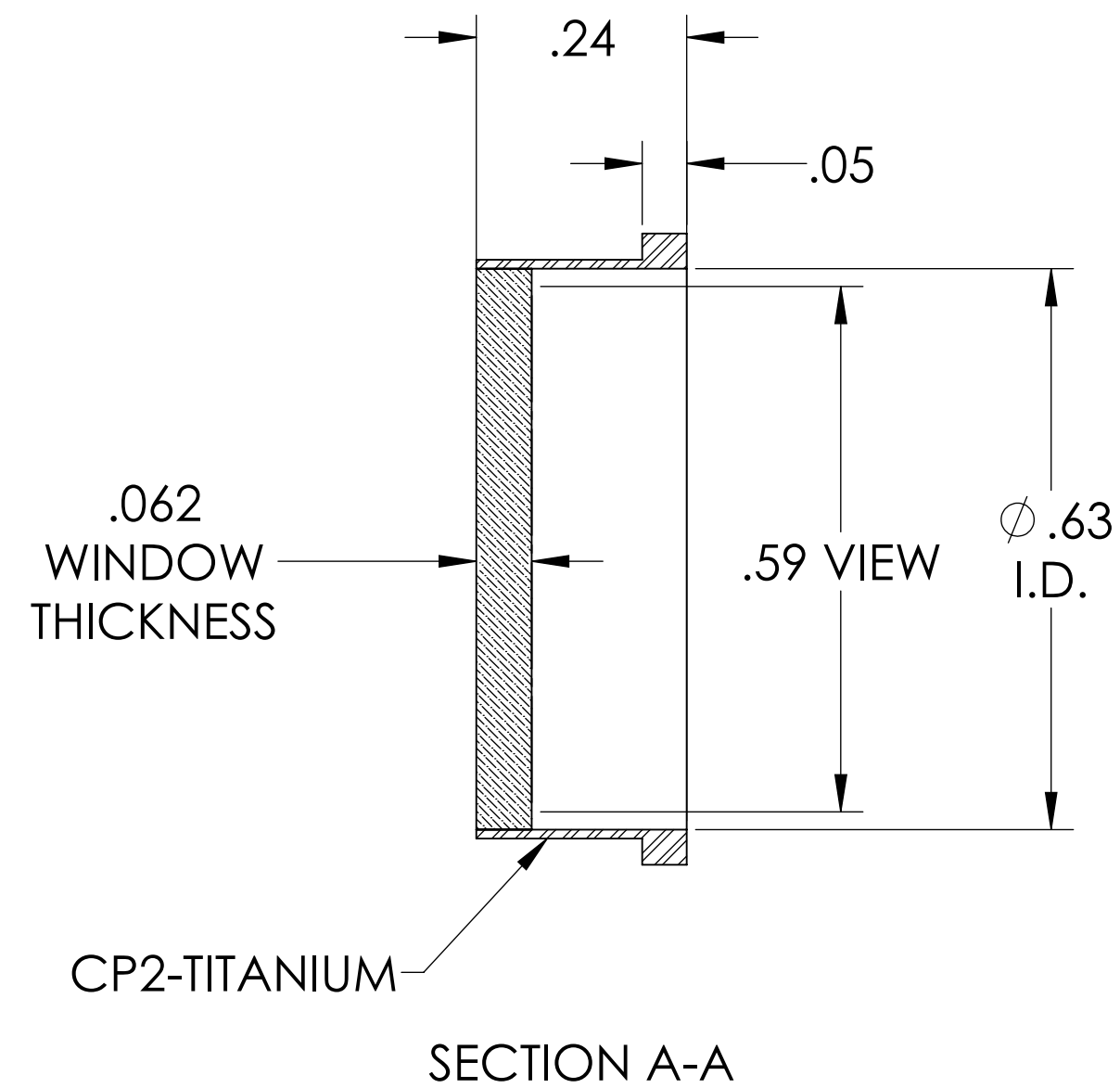
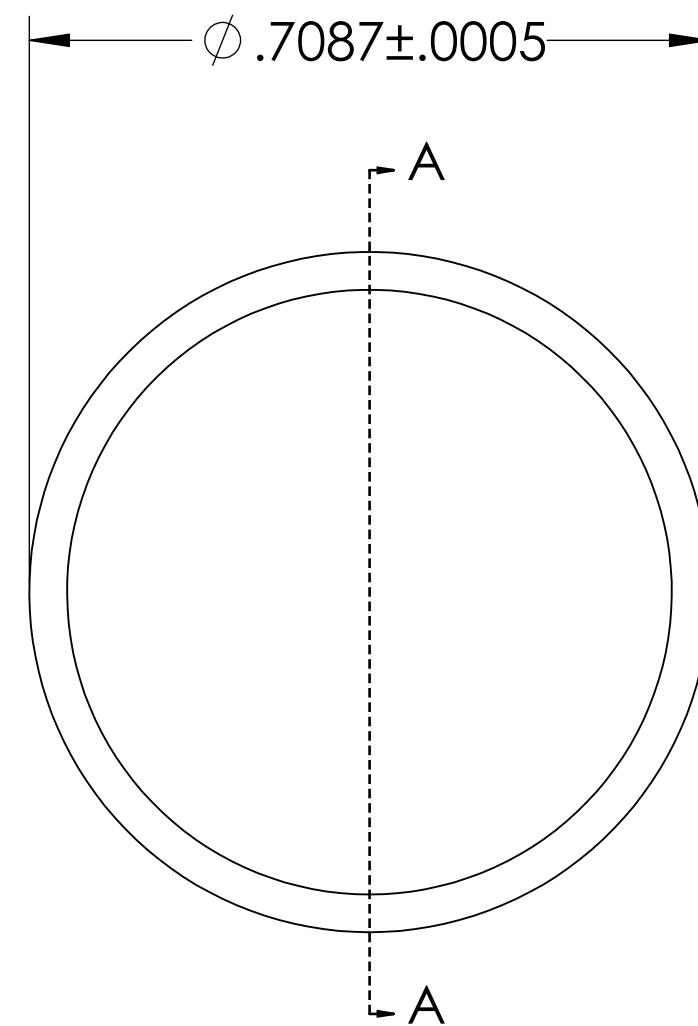

**SPECIFICATIONS:**

1. MATERIAL: SAPPHIRE
2. TWD <math>< 8\lambda</math> @ 632nm (PEAK TO VALLEY)
3. PARALLELISM <math>< 3</math> ARC-MINUTES
4. SURFACE FINISH: 20-10 SCRATCH-DIG
5. THERMAL RANGE: -100 °C TO 450 °C
6. ORIENTATION: 0°
7. LEAK RATE <math>< 1 \times 10^{-9}</math> ATM CC/SEC HE

Laser Grade Sapphire Viewport, .59" View Dia, .7087" Dia Titanium Weld Adapter

|   |   |   |           |
|---|---|---|-----------|
| UNLESS OTHERWISE SPECIFIED:             | QUOTATION #   |   | N/A       |
| DIMENSIONS ARE IN INCHES<br>TOLERANCES: | DRAWN   | NAME  | DATE      |
| ANGULAR: MACH ± 1/2°                    | WJ  | WJ  | 9/11/2015 |
| TWO PLACE DECIMAL ± .030                | CHECKED   |   | 9/11/2015 |
| THREE PLACE DECIMAL ± .015              | ENG APPR.   | WJ  | 9/11/2015 |
| MATERIAL                                | THIRD ANGLE:  |   |           |
|   |   |   |           |
| FINISH                                  | SURFACE FINISH: $\sqrt{63}$ OR BETTER                                     |   |           |
| PLATING                                 | UNLESS OTHERWISE SPECIFIED:   |   |           |
|   | ALL DIAMETERS CONCENTRIC WITHIN .005.<br>REMOVE ALL BURRS AND SHARP EDGES |   |           |
|   |   | TITLE:  |           |
|   |   | MPF PRODUCTS INC.                             |           |
|   |   | VIEWPORT<br>DUV SAPPHIRE<br>TITANIUM WELDABLE |           |
|   |   | DOWNLOADED FROM MPFPI.COM                     |           |
|   |   | DWG. NO.                                      | REV       |
|   |   | A13989-1-W                                    |           |
|   |   | Thursday, December 18, 2025 3:49:22 PM        |           |